

Environment-resistive Terminals with Transistors (Standard Type) DRT2-□D04CL(-1)/□D08CL(-1)/□D16CL(-1)

Remote I/O Terminals with High Degree of Environmental Resistance (IP67) in Product Lineup Including Economical Input, Output, and Mixed I/O Models

- Common Smart Slave functionality provides strong support for equipment operation status monitoring and effective maintenance.
- High degree of environmental resistance with dust-proof and drip-proof construction. (IP67)
- Models with one connector for two outputs are available to make easier connection with hydraulic valve devices. (Models with 16 outputs and models with 16 mixed I/O)



Smart Slave Functions

Operation time monitor (I/O only) *	Contact operation counter	Unit conduction time monitor
Total ON time monitor	Unit comments	Connected device comments
Network power supply voltage monitor	I/O power supply monitor function	Communications error log function
Input filter (input or I/O only)	Power-ON inrush current protection (input or I/O only)	
Communications speed auto-detection	No need to wire Unit power supply	Last maintenance date

* The operation time monitor can be used with the DRT2-□D04CL(-1).

Ordering Information

Specifications		I/O connections	Rated internal circuit power supply voltage	Rated I/O power supply voltage	Model			
Inputs	NPN (+ common)	Sensor I/O connector	Supplied from the communications connector	24 VDC	DRT2-ID04CL			
	PNP (- common)				DRT2-ID04CL-1			
Outputs	NPN (- common)				DRT2-OD04CL			
	PNP (+ common)				DRT2-OD04CL-1			
Inputs	NPN (+ common)	Sensor I/O connector	Supplied from the communications connector	24 VDC	DRT2-ID08CL			
	PNP (- common)				DRT2-ID08CL-1			
Outputs	NPN (- common)				DRT2-OD08CL			
	PNP (+ common)				DRT2-OD08CL-1			
Inputs	NPN (+ common)				Sensor I/O connector	Supplied from the communications connector	24 VDC	DRT2-HD16CL
	PNP (- common)							DRT2-HD16CL-1
Outputs	NPN (- common)	DRT2-WD16CL						
	PNP (+ common)	DRT2-WD16CL-1						
I/O	NPN (input: + common, output: - common)	8 inputs/ 8 outputs	Supplied from the communications connector	24 VDC				DRT2-MD16CL
	PNP (input: - common, output: + common)							DRT2-MD16CL-1

General Specifications

Item	Model	DRT2-ID04CL(-1)	DRT2-OD04CL(-1)	DRT2-ID08CL(-1)	DRT2-OD08CL(-1)	DRT2-HD16CL(-1)	DRT2-WD16CL(-1)	DRT2-MD16CL(-1)
Communications power supply voltage		11 to 25 VDC (Supplied from the communications connector)						
I/O power supply voltage		20.4 to 26.4 VDC (24 VDC -15%/+10%)						
Noise immunity		Conforms to IEC 61000-4-4 2 kV (power line)						
Communications power supply current consumption		55 mA max.		50 mA max.		55 mA max.		
Vibration resistance		10 to 60 Hz with double-amplitude of 0.7 mm, 60 to 150 Hz and 50 m/s ² in X, Y, and Z directions for 80 min each						
Shock resistance		150m/s ² , 6 directions, 3 times each						
Dielectric strength		500 VAC between isolated circuits						
Insulation resistance		20 MΩ min. (between isolated circuits)						
Ambient operating temperature		-10°C to 55°C						
Ambient operating humidity		25% to 85% (with no condensation)						
Ambient operating atmosphere		No corrosive gases						
Ambient storage temperature		-20°C to 65°C						
Degree of protection		IP67						
Mounting method		M5 screw mounting (front and back)						
Mounting strength		100 N						
Connector strength		30 N						
Screw tightening torque		Round connectors (communications, supply voltage, and I/O): 0.39 to 0.49 N·m M5 (Unit mounting from front): 1.47 to 1.96 N·m						
Weight		275 g max.		390 g max.				
I/O power supply connector		7/8-16UN						
Communications connector		M12						

Input Specifications

● 4-input Models

Item	Model	DRT2-ID04CL	DRT2-ID04CL-1
Internal I/O common		NPN	PNP
I/O points		4 inputs	
ON voltage		15 VDC min. (between each input terminal and V)	15 VDC min. (between each input terminal and G)
OFF voltage		5 VDC max. (between each input terminal and V)	5 VDC max. (between each input terminal and G)
OFF current		1.0 mA max.	
Input current		6.0 mA max. per point at 24 VDC 3.0 mA max. per point at 17 VDC	
I/O power supply voltage		20.4 to 26.4 VDC (24 VDC -15%/+10%)	
ON delay time		1.5 ms max.	
OFF delay time		1.5 ms max.	
Number of circuits per common		4 per common	

● 16-input Models

Item	Model	DRT2-HD16CL	DRT2-HD16CL-1
Internal I/O common		NPN	PNP
I/O points		16 inputs	
ON voltage		15 VDC min. (between each input terminal and V)	15 VDC min. (between each input terminal and G)
OFF voltage		5 VDC max. (between each input terminal and V)	5 VDC max. (between each input terminal and G)
OFF current		1.0 mA max.	
Input current		6.0 mA max. per point at 24 VDC 3.0 mA max. per point at 17 VDC	
I/O power supply voltage		20.4 to 26.4 VDC (24 VDC -15%/+10%)	
ON delay time		1.5 ms max.	
OFF delay time		1.5 ms max.	
Number of circuits per common		16 per common	

● 8-input Models

Item	Model	DRT2-ID08CL	DRT2-ID08CL-1
Internal I/O common		NPN	PNP
I/O points		8 inputs	
ON voltage		15 VDC min. (between each input terminal and V)	15 VDC min. (between each input terminal and G)
OFF voltage		5 VDC max. (between each input terminal and V)	5 VDC max. (between each input terminal and G)
OFF current		1.0 mA max.	
Input current		6.0 mA max. per point at 24 VDC 3.0 mA max. per point at 17 VDC	
I/O power supply voltage		20.4 to 26.4 VDC (24 VDC -15%/+10%)	
ON delay time		1.5 ms max.	
OFF delay time		1.5 ms max.	
Number of circuits per common		8 per common	

● 8-input/8-output Models

Item	Model	DRT2-MD16CL	DRT2-MD16CL-1
Internal I/O common		NPN	PNP
I/O points		8 inputs	
ON voltage		15 VDC min. (between each input terminal and V)	15 VDC min. (between each input terminal and G)
OFF voltage		5 VDC max. (between each input terminal and V)	5 VDC max. (between each input terminal and G)
OFF current		1.0 mA max.	
Input current		6.0 mA max. per point at 24 VDC 3.0 mA max. per point at 17 VDC	
I/O power supply voltage		20.4 to 26.4 VDC (24 VDC -15%/+10%)	
ON delay time		1.5 ms max.	
OFF delay time		1.5 ms max.	
Number of circuits per common		8 per common	

Output Specifications

● 4-output Models

Item	Model	DRT2-OD04CL	DRT2-OD04CL-1
Internal I/O common		NPN	PNP
I/O points		4 outputs	
Rated output current		0.5 A per point, 2.0 A per common	
Residual voltage		1.2 V max. (0.5 A DC between each output terminal and G)	1.2 V max. (0.5 A DC between each output terminal and V)
Leakage current		0.1 mA max.	
I/O power supply voltage		20.4 to 26.4 VDC (24 VDC -15%/+10%)	
ON delay time		0.5 ms max.	
OFF delay time		1.5 ms max.	
Number of circuits per common		4 per common	

● 16-output Models

Item	Model	DRT2-WD16CL	DRT2-WD16CL-1
Internal I/O common		NPN	PNP
I/O points		16 outputs	
Rated output current		0.5 A per point, 4 A per common	
I/O power supply voltage		20.4 to 26.4 VDC (24 VDC -15%/+10%)	
Residual voltage		1.2 V max. (0.5 A DC between each output terminal and G)	1.2 V max. (0.5 A DC between each output terminal and V)
Leakage current		0.1 mA max.	
I/O power supply voltage		20.4 to 26.4 VDC (24 VDC -15%/+10%)	
ON delay time		0.5 ms max.	
OFF delay time		1.5 ms max.	
Number of circuits per common		16 per common	

● 8-output Models

Item	Model	DRT2-OD08CL	DRT2-OD08CL-1
Internal I/O common		NPN	PNP
I/O points		8 outputs	
Rated output current		0.5 A per point, 4 A per common	
I/O power supply voltage		20.4 to 26.4 VDC (24 VDC -15%/+10%)	
Residual voltage		1.2 V max. (0.5 A DC between each output terminal and G)	1.2 V max. (0.5 A DC between each output terminal and V)
Leakage current		0.1 mA max.	
I/O power supply voltage		20.4 to 26.4 VDC (24 VDC -15%/+10%)	
ON delay time		0.5 ms max.	
OFF delay time		1.5 ms max.	
Number of circuits per common		8 per common	

● 8-input/8-output Models

Item	Model	DRT2-MD16CL	DRT2-MD16CL-1
Internal I/O common		NPN	PNP
I/O points		8 outputs	
Rated output current		0.5 A per point, 4 A per common	
I/O power supply voltage		20.4 to 26.4 VDC (24 VDC -15%/+10%)	
Residual voltage		1.2 V max. (0.5 A DC between each output terminal and G)	1.2 V max. (0.5 A DC between each output terminal and V)
Leakage current		0.1 mA max.	
I/O power supply voltage		20.4 to 26.4 VDC (24 VDC -15%/+10%)	
ON delay time		0.5 ms max.	
OFF delay time		1.5 ms max.	
Number of circuits per common		8 per common	

Note: Refer to Peripheral Devices on page 153 for information on applicable connectors.

(Unit: mm)

Dimensions

DRT2-ID04CL(-1)
DRT2-OD04CL(-1)

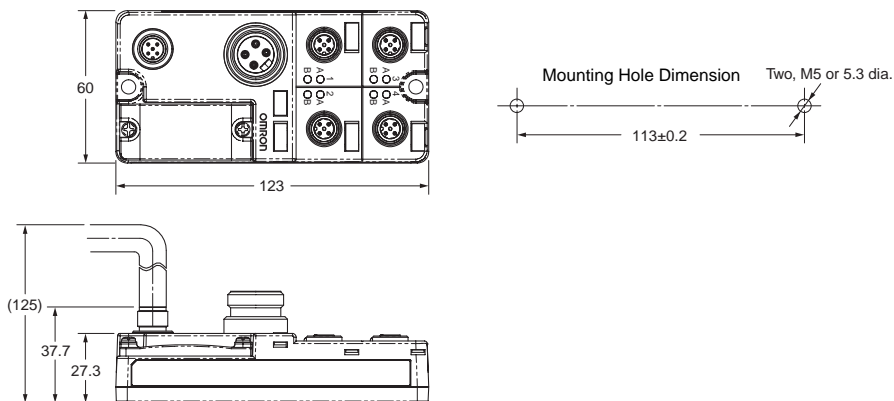

DRT2-ID08CL(-1)
DRT2-OD08CL(-1)
DRT2-HD16CL(-1)
DRT2-WD16CL(-1)
DRT2-MD16CL(-1)

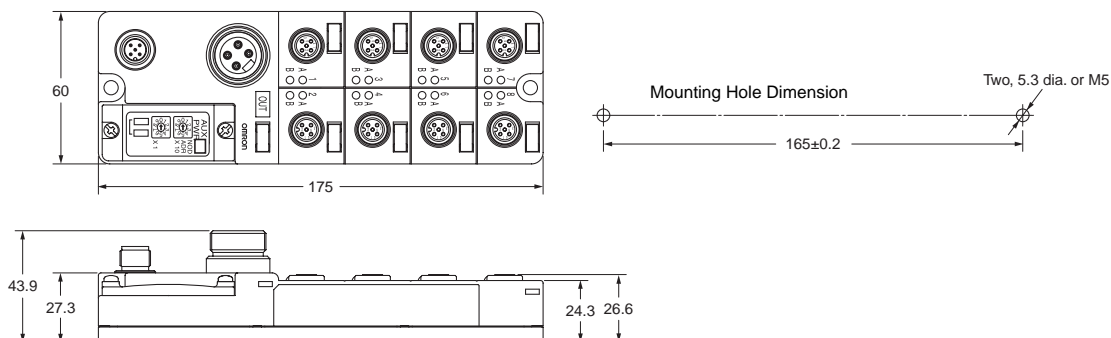

Wiring Diagrams

DRT2-ID04CL (NPN)

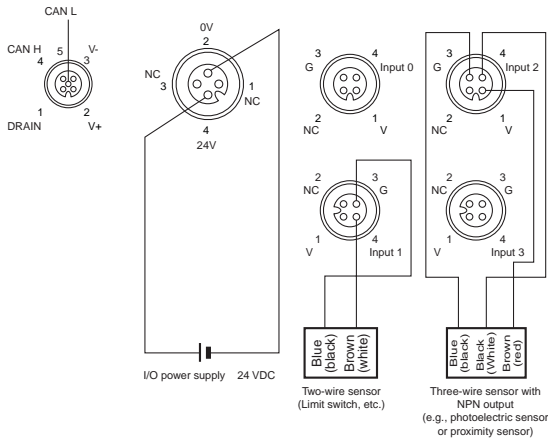

DRT2-ID04CL-1 (PNP)

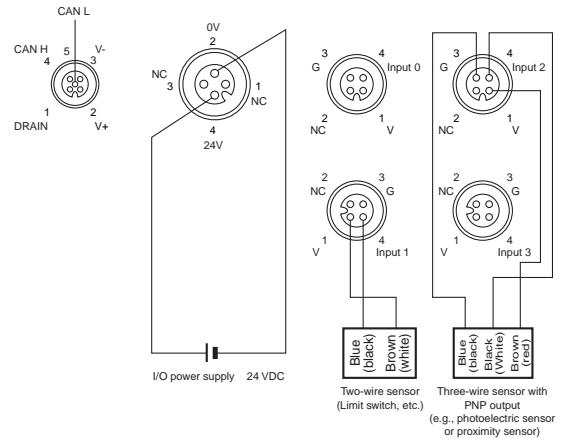

DRT2-OD04CL (NPN)

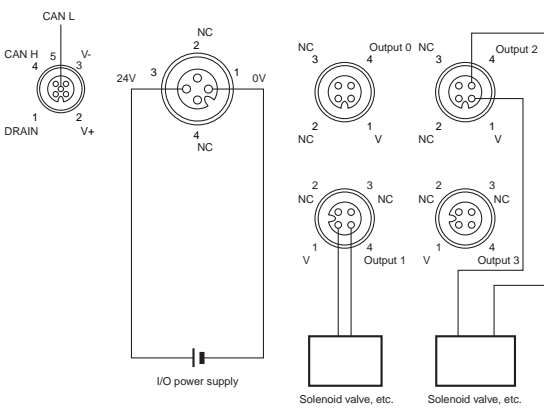

DRT2-OD04CL-1 (PNP)

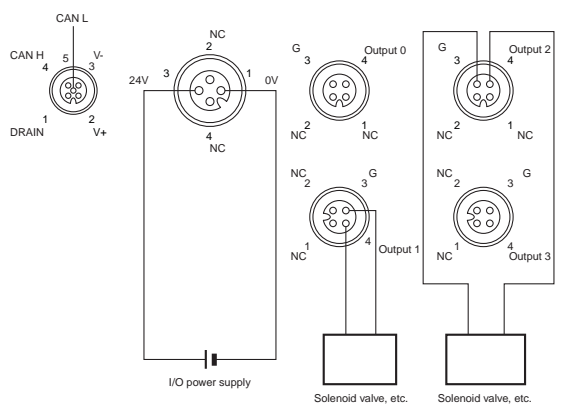

DRT2-ID08CL (NPN)

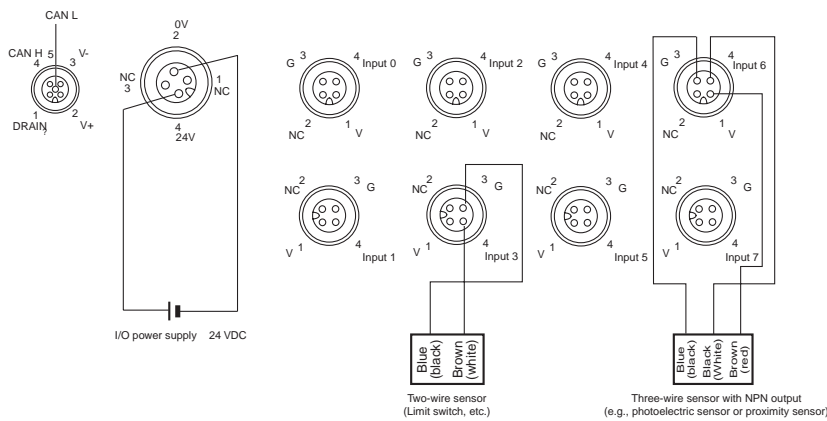

DRT2-ID08CL-1 (PNP)

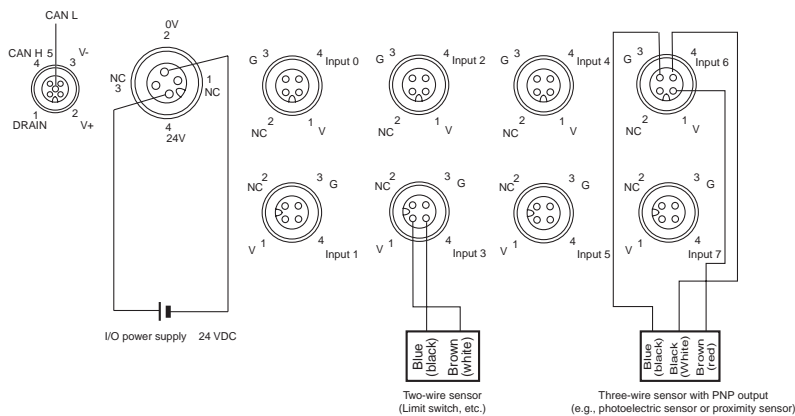

DRT2-OD08CL (NPN)

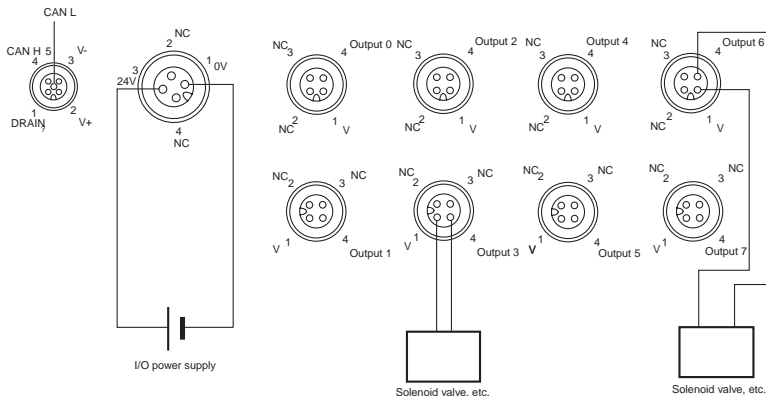

DRT2-OD08CL-1 (PNP)

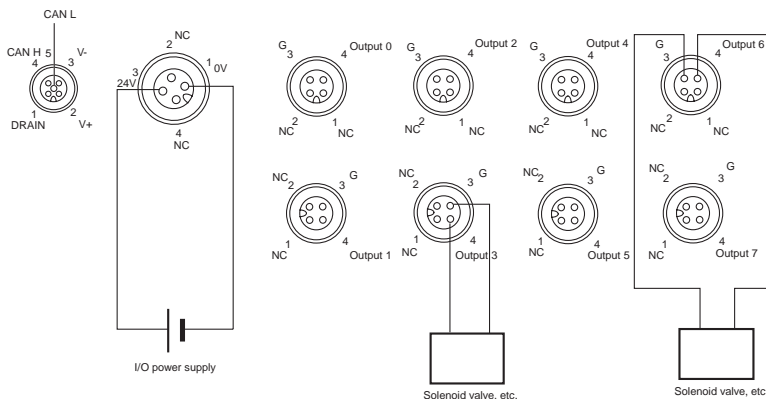

DRT2-HD16CL (NPN)

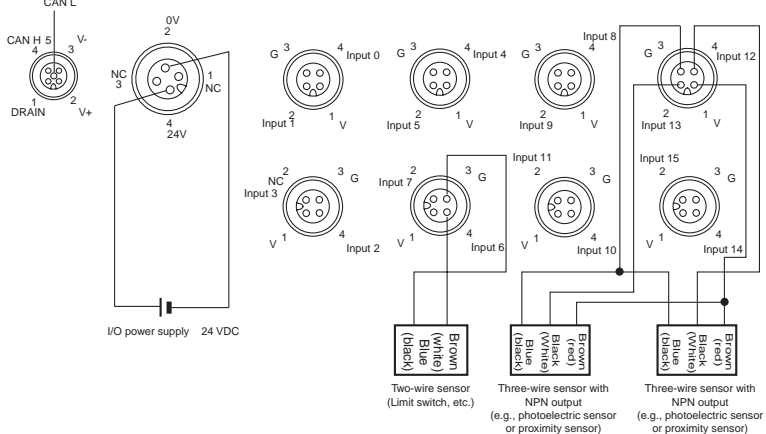

DRT2-HD16CL-1 (PNP)

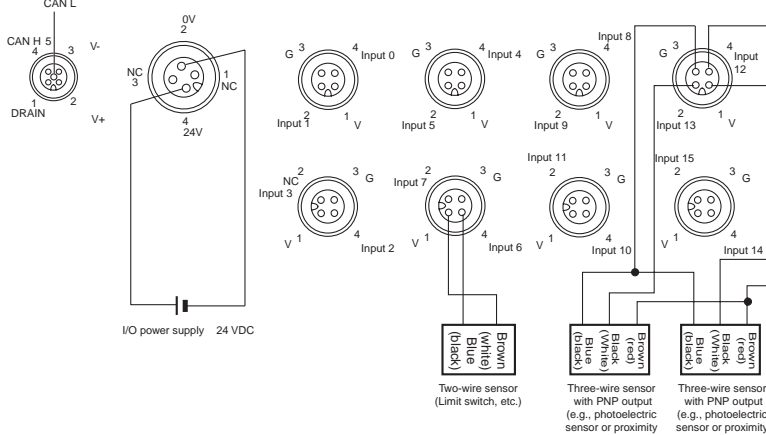

DRT2-WD16CL (NPN)

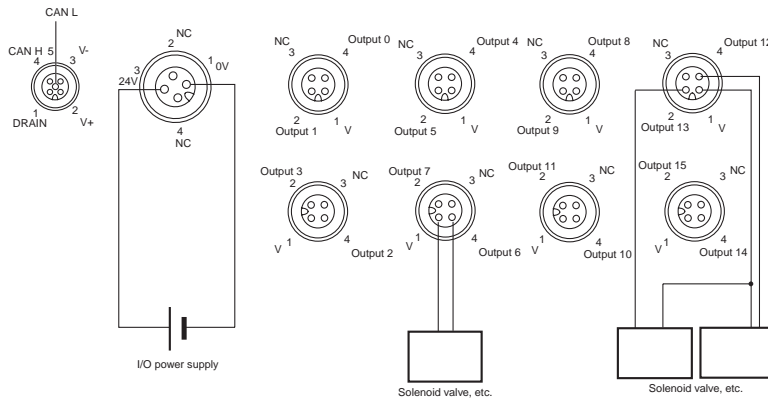

DRT2-WD16CL-1 (PNP)

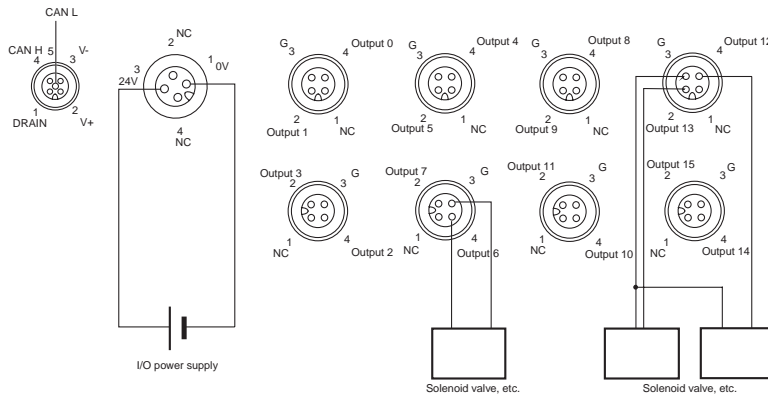

DRT2-MD16CL (NPN)

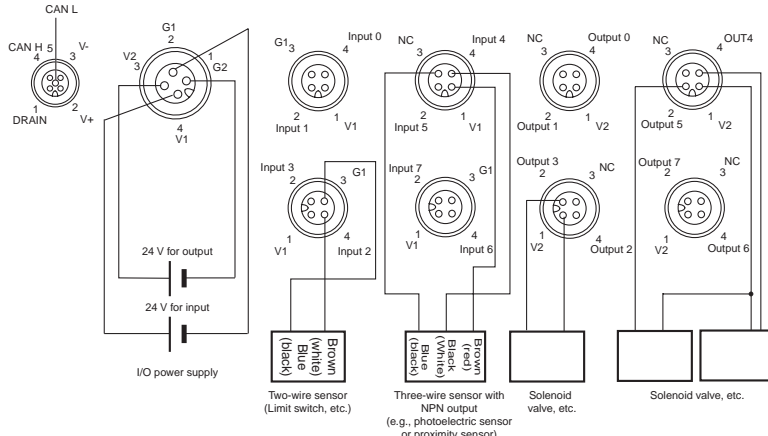

DRT2-MD16CL-1 (PNP)

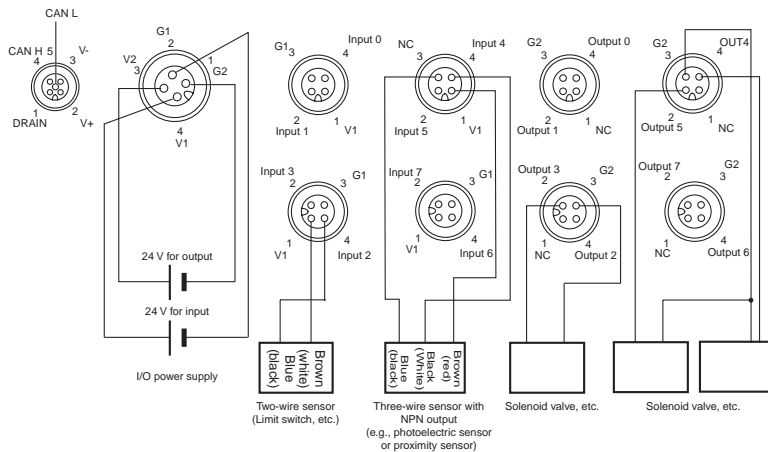

Read and Understand This Catalog

Please read and understand this catalog before purchasing the products. Please consult your OMRON representative if you have any questions or comments.

Warranty and Limitations of Liability

WARRANTY

OMRON's exclusive warranty is that the products are free from defects in materials and workmanship for a period of one year (or other period if specified) from date of sale by OMRON.

OMRON MAKES NO WARRANTY OR REPRESENTATION, EXPRESS OR IMPLIED, REGARDING NON-INFRINGEMENT, MERCHANTABILITY, OR FITNESS FOR PARTICULAR PURPOSE OF THE PRODUCTS. ANY BUYER OR USER ACKNOWLEDGES THAT THE BUYER OR USER ALONE HAS DETERMINED THAT THE PRODUCTS WILL SUITABLY MEET THE REQUIREMENTS OF THEIR INTENDED USE. OMRON DISCLAIMS ALL OTHER WARRANTIES, EXPRESS OR IMPLIED.

LIMITATIONS OF LIABILITY

OMRON SHALL NOT BE RESPONSIBLE FOR SPECIAL, INDIRECT, OR CONSEQUENTIAL DAMAGES, LOSS OF PROFITS OR COMMERCIAL LOSS IN ANY WAY CONNECTED WITH THE PRODUCTS, WHETHER SUCH CLAIM IS BASED ON CONTRACT, WARRANTY, NEGLIGENCE, OR STRICT LIABILITY.

In no event shall the responsibility of OMRON for any act exceed the individual price of the product on which liability is asserted.

IN NO EVENT SHALL OMRON BE RESPONSIBLE FOR WARRANTY, REPAIR, OR OTHER CLAIMS REGARDING THE PRODUCTS UNLESS OMRON'S ANALYSIS CONFIRMS THAT THE PRODUCTS WERE PROPERLY HANDLED, STORED, INSTALLED, AND MAINTAINED AND NOT SUBJECT TO CONTAMINATION, ABUSE, MISUSE, OR INAPPROPRIATE MODIFICATION OR REPAIR.

Application Considerations

SUITABILITY FOR USE

OMRON shall not be responsible for conformity with any standards, codes, or regulations that apply to the combination of products in the customer's application or use of the products.

At the customer's request, OMRON will provide applicable third party certification documents identifying ratings and limitations of use that apply to the products. This information by itself is not sufficient for a complete determination of the suitability of the products in combination with the end product, machine, system, or other application or use.

The following are some examples of applications for which particular attention must be given. This is not intended to be an exhaustive list of all possible uses of the products, nor is it intended to imply that the uses listed may be suitable for the products:

- Outdoor use, uses involving potential chemical contamination or electrical interference, or conditions or uses not described in this catalog.
- Nuclear energy control systems, combustion systems, railroad systems, aviation systems, medical equipment, amusement machines, vehicles, safety equipment, and installations subject to separate industry or government regulations.
- Systems, machines, and equipment that could present a risk to life or property.

Please know and observe all prohibitions of use applicable to the products.

NEVER USE THE PRODUCTS FOR AN APPLICATION INVOLVING SERIOUS RISK TO LIFE OR PROPERTY WITHOUT ENSURING THAT THE SYSTEM AS A WHOLE HAS BEEN DESIGNED TO ADDRESS THE RISKS, AND THAT THE OMRON PRODUCTS ARE PROPERLY RATED AND INSTALLED FOR THE INTENDED USE WITHIN THE OVERALL EQUIPMENT OR SYSTEM.

PROGRAMMABLE PRODUCTS

OMRON shall not be responsible for the user's programming of a programmable product, or any consequence thereof.

Disclaimers

CHANGE IN SPECIFICATIONS

Product specifications and accessories may be changed at any time based on improvements and other reasons.

It is our practice to change model numbers when published ratings or features are changed, or when significant construction changes are made. However, some specifications of the products may be changed without any notice. When in doubt, special model numbers may be assigned to fix or establish key specifications for your application on your request. Please consult with your OMRON representative at any time to confirm actual specifications of purchased products.

DIMENSIONS AND WEIGHTS

Dimensions and weights are nominal and are not to be used for manufacturing purposes, even when tolerances are shown.

PERFORMANCE DATA

Performance data given in this catalog is provided as a guide for the user in determining suitability and does not constitute a warranty. It may represent the result of OMRON's test conditions, and the users must correlate it to actual application requirements. Actual performance is subject to the OMRON Warranty and Limitations of Liability.

ERRORS AND OMISSIONS

The information in this document has been carefully checked and is believed to be accurate; however, no responsibility is assumed for clerical, typographical, or proofreading errors, or omissions.

2011.11

In the interest of product improvement, specifications are subject to change without notice.

OMRON Corporation
Industrial Automation Company

<http://www.ia.omron.com/>

(c)Copyright OMRON Corporation 2011 All Right Reserved.