

DST1 Series

Distributed Safety Terminals That Reduce Wiring.

- Lineup includes four models to accommodate various I/O types and number of I/O points.
- Monitor the safety system from Standard Controllers across the network.
- EN954-1 (Cat.4), ISO13849-1 (PLe), and IEC 61508 SIL3 certification.
- The DST1-XD0808SL-1 also supports logic operation functions for high-speed processing in applications requiring partial stopping of the safety system.



Ordering Information

List of Models

Name	No. of I/O points	Model
Safety I/O Terminals	Safety inputs: 12, test outputs: 4	DST1-ID12SL-1
	Safety inputs: 8, safety outputs (semiconductor): 8, test outputs: 4	DST1-MD16SL-1
		DST1-XD0808SL-1 *
	Safety inputs: 4, safety outputs (relay): 4, test outputs: 4	DST1-MRD08SL-1

Note: The standard DS1T Safety I/O Terminals are equipped with spring-cage terminal blocks, but screw terminal blocks are available if desired, e.g., to replace previous terminals. Refer to DeviceNet Safety Accessories.

*Use the Network Configurator Ver. 2.0 or later to make DST1-XD0808SL-1 settings.

Specifications

Certified Standards

Certification body	Standard
TÜV Rheinland	NFPA 79-2007
	IEC61508 part1-7/12.98-05.00
	IEC61131-2: 2007
	EN ISO13849-2: 2003
	EN954-1: 1996 (ISO13849-1: 1999)
	EN61000-6-4: 2007
	EN61000-6-2: 2005
UL	EN60204-1: 2006
	EN418: 1992
	ANSI RIA15.06-1999
	ANSI B11.19-2003
	UL508
	UL1604 (excluding the DST1-MRD08SL-1)
	UL1998
UL	NFPA79
	IEC61508
	CSA22.2 No.142
	CSA22.2 No.213 (excluding the DST1-MRD08SL-1)

Specifications

Item	Model	DST1-ID12SL-1	DST1-MD16SL-1	DST1-MRD08SL-1	DST1-XD0808SL-1
Communications power supply voltage		11 to 25 VDC supplied via communications connector			
I/O power supply voltage		20.4 to 26.4 VDC (24 VDC -15%/+10%)			
Current consumption	Communications power supply	24 VDC 100 mA	24 VDC 110 mA	24 VDC 100 mA	24 VDC 110 mA
	I/O power supply *	24 VDC 70 mA	24 VDC 50 mA (Input) 130 mA (Output)	24 VDC 80 mA (Input) 130 mA (Output)	24 VDC 50 mA (Input) 130 mA (Output)
Overvoltage category		II			
Noise immunity		Conforms to IEC61131-2.			
Vibration resistance		10 to 57 Hz: 0.35-mm single amplitude, 57 to 150 Hz: 50 m/s ²			
Shock resistance		150 m/s ² , 11 ms		100 m/s ² , 11 ms	150 m/s ² , 11 ms
Mounting method		35-mm DIN Track			
Ambient operating temperature		-10 to 55°C			
Ambient operating humidity		10% to 95% (with no condensation)		10% to 85% (with no condensation)	10% to 95% (with no condensation)
Ambient storage temperature		-40 to 70°C			
Degree of protection		IP20			
Weight		420 g		600 g	420 g

*Not including power consumption for external devices.

Safety Input Specifications

(Common with the DST1 Series)

Input type	Sinking inputs (PNP)
ON voltage	11 VDC min.
OFF voltage	5 VDC max.
OFF current	1 mA max.
Input current	6 mA

Safety Output Specifications (Semiconductor output)

(Common with the DST1-MD16SL-1/XD0808SL-1)

Output type	Sourcing outputs (PNP)
Rated output current	0.5 A max./output
ON residual voltage	1.2 V max.
Leakage current	0.1 mA max.

Test Output Specifications

(Common with the DST1 Series)

Output type	Sourcing outputs (PNP)
Rated output current	0.7 A max./output
ON residual voltage	1.2 V max.
Leakage current	0.1 mA max.

Safety Output Specifications (Relay Output)

(DST1-MRD08SL-1)

Applicable relays	G7SA-2A2B, EN50205 Class A	
Failure rate P level * (Reference value)	5 VDC, 1 mA	
Rated load (resistive)	2 A at 240 VAC, 2 A at 30 VDC	
Durability	Mechanical	5,000,000 operations min. (at 7,200 operations/h)
	Electrical	100,000 operations min. (at 1,800 operations/h with a resistive load)

*This value is equivalent to 300 operations/minute.

DeviceNet Safety Communications

Safety Slave communications	Max. 4 connections (Max. 2 connections for the DST1-XD0808SL-1)
-----------------------------	---

DeviceNet Slave Communications

(Common with the DST1 Series)

Standard Slave communications	Max. 2 connections
-------------------------------	--------------------

Internal Circuit Configuration

DST1-ID12SL-1

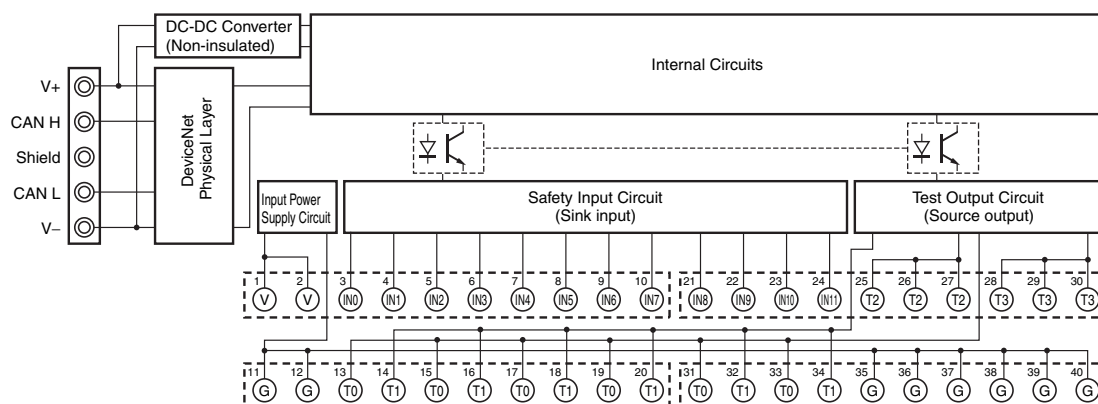

Terminal No.	Name	Function
1, 2	V	Power supply terminal (24 VDC) for input device and test output
11, 12	G	
35 to 40	G	Common terminal (Terminal No. 11, 12 and 35 to 40 are internally connected.)
3 to 10 21 to 24	IN0 to IN11	Safety input terminal
13 to 20 25 to 30 31 to 34	T0 to T3	Test output terminal

DST1-MD16SL-1 DST1-XD0808SL-1

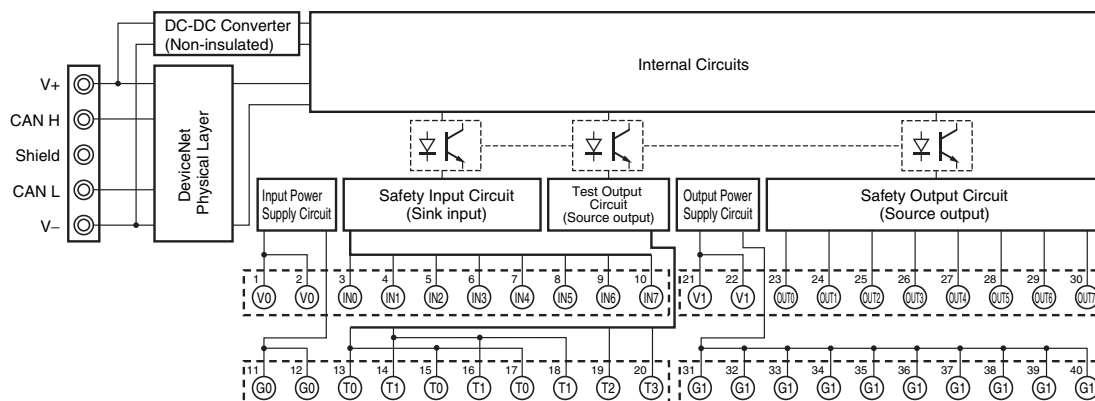

Terminal No.	Name	Function
1, 2	V0	Power supply terminal (24 VDC) for input device and test output
11, 12	G0	
3 to 10	IN0 to IN7	Safety input terminal
13 to 20	T0 to T3	Test output terminal
21, 22	V1	Power supply terminal (24 VDC) for output device
31, 32	G1	
23 to 30	OUT0 to OUT7	Safety output terminal
33 to 40	G1	Common terminal (Terminal Nos. 31 to 40 are internally connected.)

DST1-MRD08SL-1

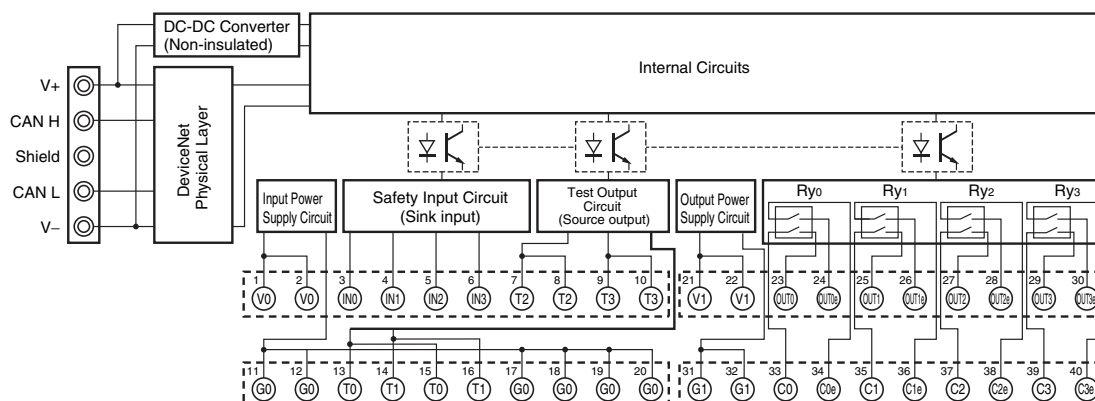

Terminal No.	Name	Function
1, 2	V0	Power supply terminal (24 VDC) for input device, test output, and monitoring the safety relay NC contact of the internal circuit
11, 12	G0	
17 to 20	G0	Common terminal (Terminal Nos. 11, 12 and 17 to 20 are internally connected.)
3 to 6	IN0 to IN3	Safety input terminal
7 to 10 13 to 16	T0 to T3	Test output terminal
21, 22	V1	Power supply terminal (24 VDC) for driving the safety relay of the internal circuit
31, 32	G1	
23 to 30 33 to 40	OUT0 to OUT3 C0 to C3 OUT0e to OUT3e C0e to C3e	Safety output terminal (The outputs of terminal No. 23/33 (OUT0) and 24/34 (OUT0e) are the same.) (The outputs of terminal No. 25/35 (OUT1) and 26/36 (OUT1e) are the same.) (The outputs of terminal No. 27/37 (OUT2) and 28/38 (OUT2e) are the same.) (The outputs of terminal No. 29/39 (OUT3) and 30/40 (OUT3e) are the same.)

Refer to the *DeviceNet Safety DST1-series Safety I/O Terminals Operation Manual* (Cat. No. Z904) for wiring examples.

Dimensions

DST1-ID12SL-1
 DST1-MD16SL-1
 DST1-XD0808SL-1

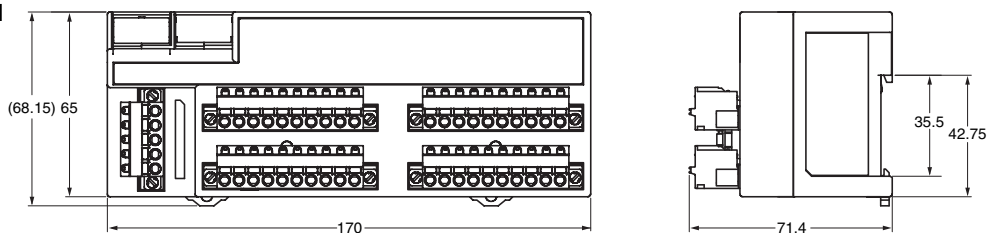

DST1-MRD08SL-1

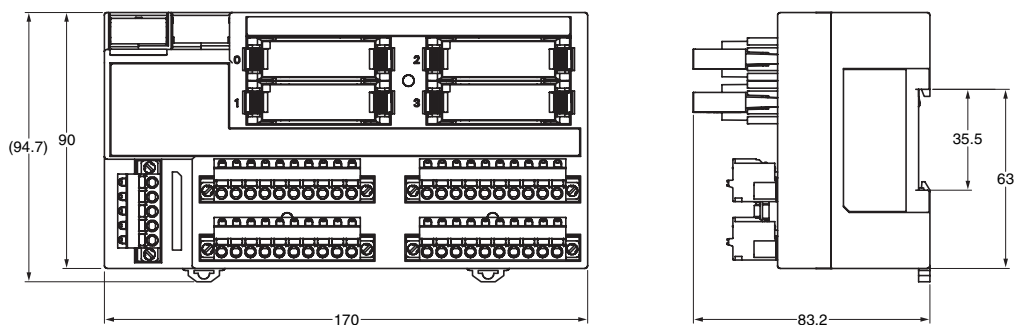

Safety Precautions

Refer to the "Safety Precautions for All DeviceNet Safety Systems" for precautions.
 Be sure to read the following user's manual for other details required for correct use of the Safety I/O Terminals
 Safety I/O Terminals User's Manual (Cat. No. Z904)

Read and Understand This Catalog

Please read and understand this catalog before purchasing the products. Please consult your OMRON representative if you have any questions or comments.

Warranty and Limitations of Liability

WARRANTY

OMRON's exclusive warranty is that the products are free from defects in materials and workmanship for a period of one year (or other period if specified) from date of sale by OMRON.

OMRON MAKES NO WARRANTY OR REPRESENTATION, EXPRESS OR IMPLIED, REGARDING NON-INFRINGEMENT, MERCHANTABILITY, OR FITNESS FOR PARTICULAR PURPOSE OF THE PRODUCTS. ANY BUYER OR USER ACKNOWLEDGES THAT THE BUYER OR USER ALONE HAS DETERMINED THAT THE PRODUCTS WILL SUITABLY MEET THE REQUIREMENTS OF THEIR INTENDED USE. OMRON DISCLAIMS ALL OTHER WARRANTIES, EXPRESS OR IMPLIED.

LIMITATIONS OF LIABILITY

OMRON SHALL NOT BE RESPONSIBLE FOR SPECIAL, INDIRECT, OR CONSEQUENTIAL DAMAGES, LOSS OF PROFITS OR COMMERCIAL LOSS IN ANY WAY CONNECTED WITH THE PRODUCTS, WHETHER SUCH CLAIM IS BASED ON CONTRACT, WARRANTY, NEGLIGENCE, OR STRICT LIABILITY.

In no event shall the responsibility of OMRON for any act exceed the individual price of the product on which liability is asserted.

IN NO EVENT SHALL OMRON BE RESPONSIBLE FOR WARRANTY, REPAIR, OR OTHER CLAIMS REGARDING THE PRODUCTS UNLESS OMRON'S ANALYSIS CONFIRMS THAT THE PRODUCTS WERE PROPERLY HANDLED, STORED, INSTALLED, AND MAINTAINED AND NOT SUBJECT TO CONTAMINATION, ABUSE, MISUSE, OR INAPPROPRIATE MODIFICATION OR REPAIR.

Application Considerations

SUITABILITY FOR USE

OMRON shall not be responsible for conformity with any standards, codes, or regulations that apply to the combination of products in the customer's application or use of the products.

At the customer's request, OMRON will provide applicable third party certification documents identifying ratings and limitations of use that apply to the products. This information by itself is not sufficient for a complete determination of the suitability of the products in combination with the end product, machine, system, or other application or use.

The following are some examples of applications for which particular attention must be given. This is not intended to be an exhaustive list of all possible uses of the products, nor is it intended to imply that the uses listed may be suitable for the products:

- Outdoor use, uses involving potential chemical contamination or electrical interference, or conditions or uses not described in this catalog.
- Nuclear energy control systems, combustion systems, railroad systems, aviation systems, medical equipment, amusement machines, vehicles, safety equipment, and installations subject to separate industry or government regulations.
- Systems, machines, and equipment that could present a risk to life or property.

Please know and observe all prohibitions of use applicable to the products.

NEVER USE THE PRODUCTS FOR AN APPLICATION INVOLVING SERIOUS RISK TO LIFE OR PROPERTY WITHOUT ENSURING THAT THE SYSTEM AS A WHOLE HAS BEEN DESIGNED TO ADDRESS THE RISKS, AND THAT THE OMRON PRODUCTS ARE PROPERLY RATED AND INSTALLED FOR THE INTENDED USE WITHIN THE OVERALL EQUIPMENT OR SYSTEM.

PROGRAMMABLE PRODUCTS

OMRON shall not be responsible for the user's programming of a programmable product, or any consequence thereof.

Disclaimers

CHANGE IN SPECIFICATIONS

Product specifications and accessories may be changed at any time based on improvements and other reasons.

It is our practice to change model numbers when published ratings or features are changed, or when significant construction changes are made. However, some specifications of the products may be changed without any notice. When in doubt, special model numbers may be assigned to fix or establish key specifications for your application on your request. Please consult with your OMRON representative at any time to confirm actual specifications of purchased products.

DIMENSIONS AND WEIGHTS

Dimensions and weights are nominal and are not to be used for manufacturing purposes, even when tolerances are shown.

PERFORMANCE DATA

Performance data given in this catalog is provided as a guide for the user in determining suitability and does not constitute a warranty. It may represent the result of OMRON's test conditions, and the users must correlate it to actual application requirements. Actual performance is subject to the OMRON Warranty and Limitations of Liability.

ERRORS AND OMISSIONS

The information in this document has been carefully checked and is believed to be accurate; however, no responsibility is assumed for clerical, typographical, or proofreading errors, or omissions.

2012.7

In the interest of product improvement, specifications are subject to change without notice.

OMRON Corporation
Industrial Automation Company

<http://www.ia.omron.com/>

(c)Copyright OMRON Corporation 2012 All Right Reserved.