

MODEL	Q6TE-18S-U-JE
MODEL CODE	13JT72
IB(NA)-0800204-C (1103)	

Spring Clamp Terminal Block Model Q6TE-18S User's Manual

1. Overview

This manual explains how to use the spring clamp terminal block model Q6TE-18S (hereinafter referred to as the Q6TE-18S).

The Q6TE-18S shall be used attached to a Q-Series terminal block-type I/O module or an intelligent function module. Since the Q6TE-18S uses a spring clamp, it does not require screw-tightening, which greatly reduces the number of wiring procedures.

Before using the product, please read "Safety Guidelines" that is supplied with the base unit.

2. Compatible Models

The Q6TE-18S can be used with the following models:

Model type	Model name					
I/O module	QX10	QX28	QX40	QX40-S1	QX70	QX80
	QY10	QY18A	QY22	QY40P	QY50	QY68A
	QY70	QY80	QX48Y57	QI60		
Intelligent function module	Q62DA	Q64DA	Q68DAV	Q68DAI		
	Q64AD	Q68ADV	Q68ADI			
	Q64TCRT	Q64TCRTBW	Q64RD			

3. Specifications

Item	Specifications
Applicable wire size	0.3 to 1.5 mm ² (AWG22 to 16)
Wire strip length	8 to 11 mm
Terminal block mounting screw tightening torque range	0.66 to 0.89 N•m
Weight	0.07kg

4. Removal of Terminal Block and Installation of Q6TE-18S

(1) Removal of terminal block

- Unscrew the two terminal block mounting screws situated at the top and bottom of the terminal block.
- Gently remove the terminal block.

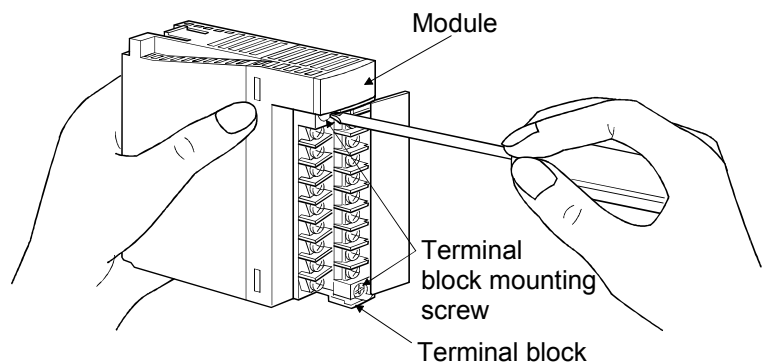

(2) Installation of Q6TE-18S

- Attach the Q6TE-18S to the module.
- Tighten the terminal block mounting screws within the specified torque range.

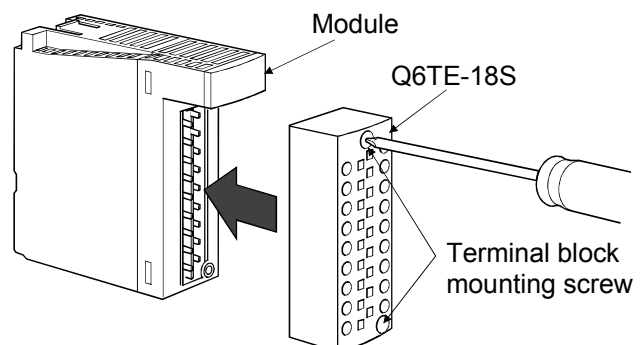

5. Cable Installation Procedure

(1) Cable Installation

- Insert the tool vertically all the way inside the square shaped hole of the Q6TE-18S.
- Insert the wire or the bar solderless terminal into the circular shaped hole, and remove the tool from the hole.
- Check that the wire or the bar solderless terminal is firmly clamped by pulling it lightly.

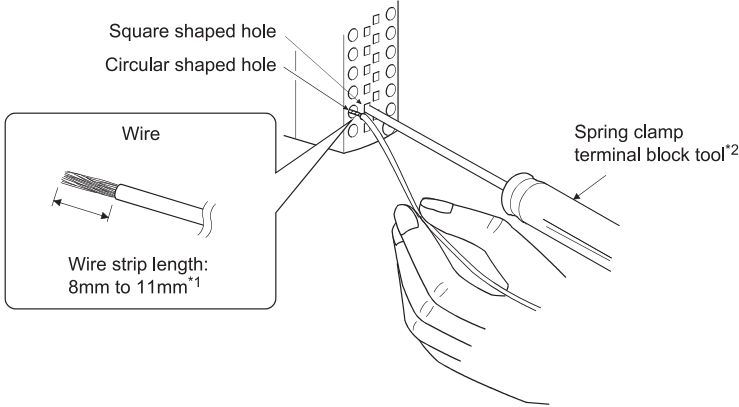

- *1: Check that the wire strip length is between 8mm to 11mm.
If the wire strip length is too long, the exposed conductive part may cause electric shock or short circuit. If the wire strip length is too short, it may result in insufficient contact of the conductive part.
- *2: When installing or removing the cable, follow the instructions below. Failure to do so may cause damage of the spring clamp terminal part or the terminal block resin part.
- Use a dedicated tool for a spring clamp terminal block.
 - Do not insert the wire or the bar solderless terminal before inserting the tool into the square shaped hole.
 - Insert the tool vertically into the hole.

(2) Cable removal

- Insert the tool vertically all the way inside the square shaped hole of the Q6TE-18S.
- Pull the wire or the bar solderless terminal out of the hole.

6. External Connections

The terminal numbers of the Q6TE-18S correspond to the terminal numbers on the compatible modules.

For the signal names corresponding to the terminal numbers when an external device is connected, please refer to the User's Manual for the module to be used.

7. List of Introductory Products

Product name	Model name	Applicable wire size	Contact
Tool (for insertion)	KD-5339	—	Mitsubishi Electric System Service Co., Ltd.
Bar solderless terminal ^{*3}	FA-VTC125T9	0.3 to 1.65mm ²	Mitsubishi Electric Engineering Co., Ltd.
	FA-VTCW125T9 ^{*4}		
Tool dedicated for bar solderless terminal	NH79	—	
Bar solderless terminal ^{*3}	TE 0.5-8, TE 0.5-10	0.5mm ²	NICHIFU TERMINAL MFG. Co., Ltd.
	TE 0.75-8, TE 0.75-10	0.75mm ²	
	TE 1.0-8, TE 1.0-10	0.9 to 1.0mm ²	
	TE 1.5-8, TE 1.5-10	1.25 to 1.5 mm ²	
Tool dedicated for bar solderless terminal	NH79	—	

*3: Use this product when doing the terminal treatment of the wire and inserting it into the spring clamp terminal block.

*4: Use this product when inserting two wires into one terminal.

8. External Dimensions

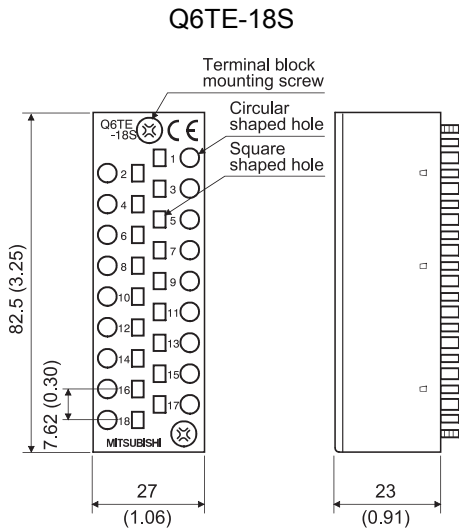

Installed on a module (Example: QX10)

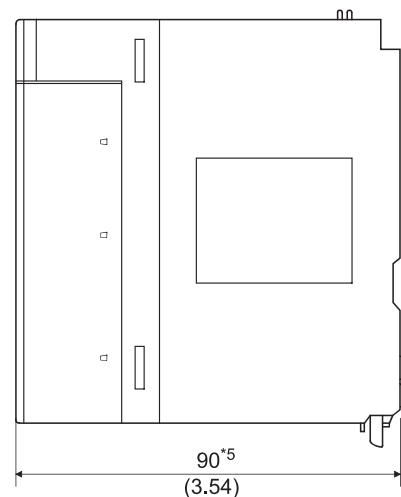

Unit: mm(inch)

*5: The depth of the module installed with a Q6TE-18S is equivalent with the factory default dimensions for that module.