

WS0-XTIO84202/WS0-XTDI80202  
**Safety Controller Safety I/O Module  
 User's Manual (Hardware)**

Mitsubishi Electric Corporation  
 2-7-3 Marunouchi, Chiyoda-ku, Tokyo, Japan  
 Mitsubishi Electric Europe BV  
 Gothaer strasse 8, 40880 Ratingen, Germany  
 All rights reserved • Specified product properties and technical data do not represent a guarantee declaration.

MODEL	WS-IO-U-HW-E
MODEL CODE	13JZ92
IB(NA)-0800529ENG-B(1407)SICK	

© 2014 MITSUBISHI ELECTRIC CORPORATION

### Precautions regarding warranty and specifications

MELSEC-WS series products were jointly developed and manufactured by Mitsubishi and SICK AG, Industrial Safety Systems, in Germany. Note that there are some precautions regarding warranty and specifications of MELSEC-WS series products.

<Warranty>

- The gratis warranty term of the product shall be for one (1) year after the date of delivery or for eighteen (18) months after manufacturing, whichever is less.
- The onerous repair term after discontinuation of production shall be for four (4) years.
- Mitsubishi shall mainly replace the product that needs a repair.
- It may take some time to respond to the problem or repair the product depending on the condition and timing.

<Specifications>

- General specifications of the products differ.

	MELSEC-WS	MELSEC-Q	MELSEC-QS
Operating ambient temperature <i>Température ambiante de fonctionnement</i>	-25 to 55°C <sup>*1</sup> -25 à 55°C <sup>*1</sup>	0 to 55°C 0 à 55°C	0 to 55°C 0 à 55°C
Operating ambient humidity	10 to 95%RH	5 to 95%RH	5 to 95%RH
Storage ambient temperature	-25 to 70°C	-25 to 75°C	-40 to 75°C
Storage ambient humidity	10 to 95%RH	5 to 95%RH	5 to 95%RH

\*1: When the WS0-GCC100202 is included in the system, operating ambient temperature will be 0 to 55°C.

\*1: Avec un module WS0-GCC100202 inclus dans le système, la température ambiante de service est de 0 à 55°C.

EMC standards that are applicable to the products differ.

	MELSEC-WS	MELSEC-Q, MELSEC-QS
EMC standards	EN 61000-6-2, EN 55011	EN 61131-2

## 1 About this document

This document is the original manual.

### 1.1 Documentations for the MELSEC-WS system

This manual describes the mounting of the safety I/O modules (WS0-XTIO and WS0-XTDI) of a MELSEC-WS safety controller.

Mounting of the MELSEC-WS CPU modules (WS0-CPU0 and WS0-CPU1), network modules (WS0-GETH and WS0-GCC1) and the relay output module (WS0-4RO) is described in separate manuals.

The installation, configuration and commissioning of the MELSEC-WS safety controller are described in the "Safety Controller User's Manual" and "Safety Controller Setting and Monitoring Tool Operating Manual".

Title	Number
Safety Controller User's Manual	WS-CPU-U-E (13JZ32)
Safety Controller Ethernet Interface User's Manual	WS-ET-U-E (13JZ33)
Safety Controller CC-Link Interface User's Manual	WS-CC-U-E (13JZ45)
Safety Controller Setting and Monitoring Tool Operating Manual	SW1DNNWS0ADR-B-O-E (13JU67)

### 1.2 Function of this document

This manual instructs the technical staff of the machine manufacturer and/or of the machine operator on the safe mounting of the safety I/O module of the MELSEC-WS safety controller.

In addition mounting protective devices also requires specific technical skills which are not detailed in this documentation.

This manual does not provide manuals for operating the machine in which the safety controller is, or will be, integrated. Information of this kind will be found in the manuals for the machine.

## 2 On safety

This chapter deals with your own safety and the safety of the equipment operators.

- Please read this chapter carefully before beginning with the installation.

### 2.1 Qualified safety personnel

The MELSEC-WS safety controller may only be installed by qualified safety personnel.

Qualified safety personnel are defined as persons who ...

- have undergone the appropriate technical training **and**
- who have been instructed by the responsible machine operator in the operation of the machine and the current valid safety guidelines **and**
- are familiar with the Industrial Safety and Health Act and well-recognized technical cases relevant to the operations and can assess the industrial safety on the power-driven equipment **and**
- have access to the MELSEC-WS manuals and have read and familiarized themselves with them **and**
- have access to the manuals for the protective devices (e.g. light curtains) connected to the safety controller and have read and familiarized themselves with them.

### 2.2 Applications of the device

The MELSEC-WS safety controller is a configurable controller for safety applications. It can be used

- in accordance with IEC 61508 to SIL 3
- in accordance with IEC 62061 to SILCL 3
- in accordance with EN/ISO 13849-1 up to Performance Level e

The degree of safety actually attained depends on the external circuit, the realization of the wiring, the parameter configuration, the choice of the pick-ups and their location at the machine.

Opto-electronic and tactile safety sensors (e.g. light curtains, laser scanners, safety switches, sensors, encoder, emergency-stop buttons) are connected to the safety controller and are linked logically. The corresponding actuators of the machines or systems can be switched off safely via the switching outputs of the safety controller.

### 2.3 Correct use



**The MELSEC-WS safety controller fulfils the requirements of Class A (industrial applications) in accordance with the "Interference emission" basic specifications!**

**Le contrôleur de sécurité MELSEC-WS a été conçu en conformité aux exigences des appareils de Classe A (applications industrielles) pour ce qui concerne les spécifications de base dans le domaine des "émissions d'interférences" !**

The MELSEC-WS safety controller is therefore only suitable for use in an industrial environment and not for private use.

**Le contrôleur de sécurité MELSEC-WS peut donc s'utiliser dans un environnement industriel mais n'a pas été prévu pour un usage domestique.**

The MELSEC-WS safety controller may only be used within specific operating limits (voltage, temperature, etc., refer to the technical data and to the section "Application areas of the device"). It may only be used by qualified safety personnel and only at the machine at which it was mounted and initially commissioned by qualified safety personnel in accordance with the "Safety Controller User's Manual".

The modules of the MELSEC-WS safety controller conform to Class A, Group 1, in accordance with EN 55011. Group 1 encompasses all the ISM devices in which intentionally generated and/or used conductor-bound RF energy that is required for the inner function of the device itself occurs.

Mitsubishi Electric Corporation accepts no claims for liability if the equipment is used in any other way or if modifications are made to the device, even in the context of mounting and installation.

UL/CSA applications:

- Use 60°C/75°C conductors.
- The terminal tightening torque must be 4.4-5.3 lbs in.
- To be used in a Pollution Degree 2 environment only.
- The module shall be supplied by an isolating power source protected by an UL248 fuse, rating 42.4VDC which is the maximum voltage requirements of UL508.

- The safety functions are not evaluated by UL. The approval is accomplished according to UL508, general use applications.

Applications UL/CSA:

- *Utiliser des conducteurs 60°C/75°C.*
- *Le couple de serrage des bornes doit être de 5-7 lbs in.*
- *À utiliser uniquement en environnement polluant de degré 2.*
- *La prise mémoire et le module CPU doivent être alimentés à partir d'une source isolée protégé par un fusible UL248, d'un tension nominale de 42,2V cc, ce qui est le maximum admissible pour UL508.*
- *Les fonctions de sécurité n'ont pas été évaluées par UL. L'agrément a été accordé selon UL508 pour applications universelles.*

### 2.4 General protective notes and protective measures



**Observe the protective notes and measures!  
 Respecter les consignes de sécurité et mesures de protection!**

Please observe the following items in order to ensure proper use of the MELSEC-WS safety controller.  
*Pour garantir une utilisation correcte du contrôleur de sécurité MELSEC-WS, veuillez observer les points suivants.*

- When mounting, installing and using the MELSEC-WS safety controller, observe the standards and directives applicable in your country.
- The national/international rules and regulations apply to the installation, use and periodic technical inspection of the MELSEC-WS safety controller, in particular:
  - Machinery Directive 2006/42/EC
  - EMC Directive 2004/108/EC
  - Use of Work Equipment Directive 2009/104/EC
  - Low-Voltage Directive 2006/95/EC
  - The work safety regulations/safety rules
- Manufacturers and owners of the machine on which a MELSEC-WS safety controller is used are responsible for obtaining and observing all applicable safety regulations and rules.
- It is imperative that the notices, in particular the test notice of the manual must be observed.
- The tests must be carried out by qualified safety personnel or specially qualified and authorised personnel and must be recorded and documented to ensure that the tests can be reconstructed and retraced at any time by third parties.

### 2.5 Disposal

Disposal of unusable or irreparable devices should always occur in accordance with the applicable country-specific waste-disposal regulations (e.g. European Waste Code 16 02 14).

## 3 Conditions of use for the product

- (1) Although MELCO has obtained the certification for Product's compliance to the international safety standards IEC 61508, EN 954-1/ISO 13849-1 from TÜV Rheinland, this fact does not guarantee that Product will be free from any malfunction or failure. The user of this Product shall comply with any and all applicable safety standard, regulation or law and take appropriate safety measures for the system in which the Product is installed or used and shall take the second or third safety measures other than the Product. MELCO is not liable for damages that could have been prevented by compliance with any applicable safety standard, regulation or law.
- (2) MELCO prohibits the use of Products with or in any application involving, and MELCO shall not be liable for a default, a liability for defect warranty, a quality assurance, negligence or other tort and a product liability in these applications.
  - 1) power plants,
  - 2) trains, railway systems, airplanes, airline operations, other transportation systems,
  - 3) hospitals, medical care, dialysis and life support facilities or equipment,
  - 4) amusement equipment,
  - 5) incineration and fuel devices,
  - 6) handling of nuclear or hazardous materials or chemicals,
  - 7) mining and drilling,
  - 8) and other applications where the level of risk to human life, health or property are elevated.

## 4 Product description

### 4.1 Description

Notes:

- The safety I/O modules can only be used in conjunction with a CPU module (see the Safety Controller Setting and Monitoring Tool Operating Manual).
- It is possible to use several safety I/O modules at the same time (in total max. 12 safety I/O modules, see the Safety Controller User's Manual).

#### 4.1.1 Safety I/O combined module WS0-XTIO

The WS0-XTIO module is an input/output extension with 8 safe inputs and 4 safe outputs. It fulfils the following tasks:

- Monitoring of the connected sensor equipment
- Passing on the input information to the CPU module
- Receiving the control signals from the CPU module and corresponding switching of the outputs
- Fast Shut Off
- Fast Shut Off with bypass (firmware version V2.00.0 or higher. See the Safety Controller Setting and Monitoring Tool Operating Manual.)
- Test pulse outputs (Q1-Q4) that can be activated and de-activated as required (firmware version V2.00.0 or higher. See the Safety Controller Setting and Monitoring Tool Operating Manual)

The voltage supply for the internal logic and the test outputs is provided via the internal FLEXBUS+ bus.

The voltage supply for the outputs Q1 ... Q4 on the WS0-XTIO must be provided directly via A1/A2 on the related module.

One WS0-XTIO has two test pulse generators. Short-circuits between the test outputs X1 and X2 are detected.

#### 4.1.2 Safety input module WS0-XTDI

The WS0-XTDI module is the input extension with 8 safe inputs. It fulfils the following tasks:

- Monitoring of the connected sensor equipment
- Passing on the input information to the CPU module

The voltage supply is provided via the internal FLEXBUS+ bus.

One WS0-XTDI has two test pulse generators. Here one test pulse generator is responsible for the odd test outputs X1, X3, X5 and X7, the other for the even test outputs X2, X4, X6 and X8.



**ATTENTION** WS0-XTDI recognises short-circuits between odd-numbered (X1, X3, X5, X7) and even-numbered (X2, X4, X6, X8) test pulse outputs if the test gaps <4ms.

If the test gaps ≥ 4ms, the short-circuits are not always recognize in every case.

Short-circuits under the odd-numbered (X1, X3, X5, X7) test pulse outputs or under the even-numbered (X2, X4, X6, X8) test pulse outputs are not recognize.

- Take this into account for the wiring, e.g. by separate routing or sheathing lines.

*Le WS0-XTDI reconnaît les court-circuits entre les sorties d'impulsions d'essai impaires (X1, X3, X5, X7) et paires (X2, X4, X6, X8) pour des intervalles entre essais < 4ms. Pour les intervalles entre essais ≥ 4ms, les court-circuits ne sont pas toujours reconnus dans tous les cas.*

*Les court-circuits aux sorties d'impulsions d'essai impaires (X1, X3, X5, X7) ou aux sorties d'impulsions d'essai paires (X2, X4, X6, X8) ne sont pas reconnus.*

- *Ceci doit être pris en compte lors du câblage, en prévoyant des trajets séparés ou des gainages.*

## 4.2 Display elements

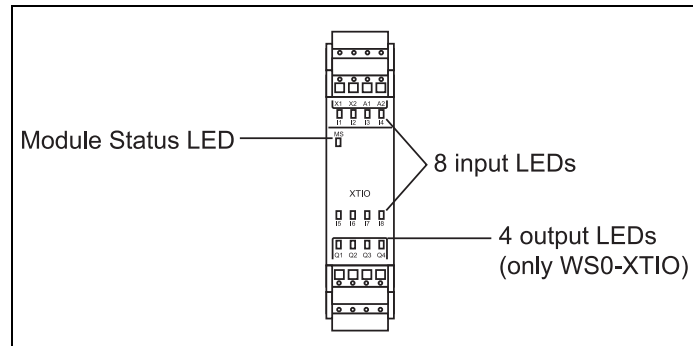

### 4.2.1 Displays of the MS LED

MS LED	Meaning
○	Supply voltage lies outside range
⊛ red/green (1Hz)	Recoverable external error
⊛ green (1Hz)	System is in Stop state
● green	System is in Run state
⊛ red (1Hz)	Configuration required
⊛ red (2Hz)	Critical error in the system, possibly in this module. Application is stopped. All outputs are switched off.
● red	Critical error in the system, possibly in another module. Application is stopped. All outputs are switched off.

Symbol meaning:

○: LED Off, ●: LED Lights up, ⊛: LED Flashes

### 4.2.2 Displays of the input/output LEDs

Input LEDs (I1 ... I8) Output LEDs (Q1 ... Q4) (only WS0-XTIO)	Meaning
○	Input/output is inactive.
● green	Input/output is active.
⊛ green (1Hz) synchronous with the red MS LED	Input/output is inactive and there is a correctable error.
⊛ green (1Hz) alternating with the red MS LED	Input/output is active and there is a correctable error.

## 4.3 Terminal assignment

### Affectation des bornes

#### 4.3.1 Terminal assignment WS0-XTIO

Module Module	Terminal Borne	Assignment Affectation
	X1/X2	Test outputs 1 and 2 Sorties d'essai 1 et 2
	I1 ... I4	Inputs 1 to 4 Entrées 1 à 4
	A1	24V
	A2	GND
	I5 ... I8	Inputs 5 to 8 Entrées 5 à 8
	Q1 ... Q4	Outputs 1 to 4 Sorties 1 à 4

#### 4.3.2 Terminal assignment WS0-XTDI

##### Affectation des bornes WS0-XTDI

Module Module	Terminal Borne	Assignment Affectation
	X1/X3	Test output 1 (test signal generator 1) Sortie d'essai 1 (Générateur de signal d'essai 1)
	X2/X4	Test output 2 (test signal generator 2) Sortie d'essai 2 (Générateur de signal d'essai 2)
	I1 ... I4	Inputs 1 to 4 Entrées 1 à 4
	I5 ... I8	Inputs 5 to 8 Entrées 5 à 8
	X5/X7	Test output 1 (test signal generator 1) Sortie d'essai 1 (Générateur de signal d'essai 1)
	X6/X8	Test output 2 (test signal generator 2) Sortie d'essai 2 (Générateur de signal d'essai 2)

### 4.4 Wiring example

Wiring of the emergency stop pushbuttons, start switches, stop switches, and reset switches

- Dual-channel wiring (with test pulse outputs)<sup>\*1</sup>

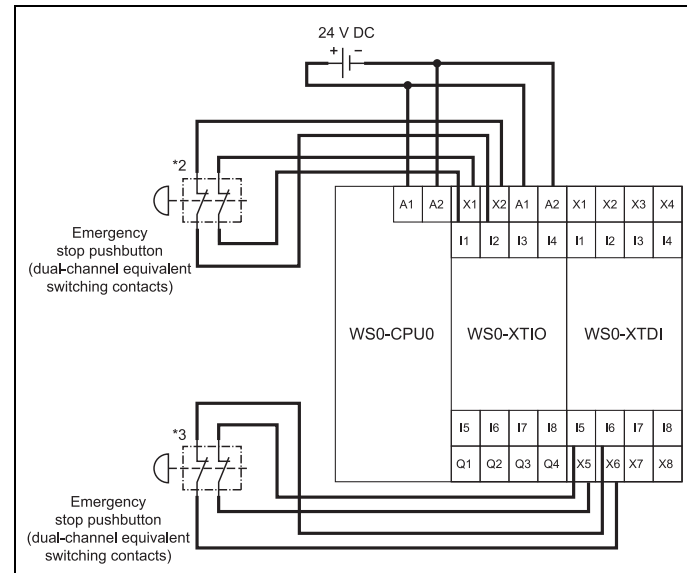

- \*1: Use the following terminal combinations for dual-channel input wiring.  
WS0-XTIO: ((I1 and X1) (I2 and X2)), ((I3 and X1) (I4 and X2)), ((I5 and X1) (I6 and X2)), ((I7 and X1) (I8 and X2))  
WS0-XTDI: ((I1 and X1) (I2 and X2)), ((I3 and X3) (I4 and X4)) to ((I7 and X7) (I8 and X8))

- \*2: Connect an emergency stop pushbutton (with dual-channel equivalent switching contacts for direct operation) between the I1 to I8 (input) terminals and the X1 and X2 (test pulse output) terminals.

- \*3: Connect an emergency stop pushbutton (with dual-channel equivalent switching contacts for direct operation) between the I1 to I8 (input) terminals and the X1 to X8 (test pulse output) terminals.

- \*1: Utiliser les combinaisons de bornes ci-après pour le câblage d'entrée double-voie.

WS0-XTIO: ((I1 and X1) (I2 and X2)), ((I3 and X1) (I4 and X2)), ((I5 and X1) (I6 and X2)), ((I7 and X1) (I8 and X2))  
WS0-XTDI: ((I1 and X1) (I2 and X2)), ((I3 and X3) (I4 and X4)) à ((I7 and X7) (I8 and X8))

- \*2: Raccorder un bouton-poussoir d'arrêt d'urgence (avec contacts de commutation équivalente sur double canal pour actionnement direct) entre les bornes I1 à I8 (entrée) et les bornes X1 et X2 (sortie d'impulsions d'essai).

- \*3: Raccorder un bouton-poussoir d'arrêt d'urgence (avec contacts de commutation équivalente sur double canal pour actionnement direct) entre les bornes I1 à I8 (entrée) et les bornes X1 à X8 (sortie d'impulsions d'essai).

## 5 Mounting/Dismantling



**ATTENTION** The MELSEC-WS safety controller is only suitable for mounting in a control cabinet with at least IP 54 degree of protection.

While supply voltage is applied, modules must not be plugged to nor be removed from the MELSEC-WS safety controller.

Le contrôleur de sécurité MELSEC-WS ne peut être installé que dans une armoire de commande avec un degré de protection IP 54 ou mieux.

Quand la tension d'alimentation est appliquée, les modules ne doivent pas être enfilés sur ou retirés du contrôleur de sécurité MELSEC-WS.

### 5.1 Mounting the modules

- In a MELSEC-WS safety controller, the WS0-CPU0 or WS0-CPU1 is positioned at the far left and the two optional network modules follow directly. Only then do the safety I/O modules follow. The WS0-4RO module has to be mounted at the far right.
- The modules are located in a 22.5mm wide modular system for 35mm DIN rails to IEC/EN 60715.
- The connection between the modules is effected by means of the plug connection integrated in the housing.
- Mount the modules in accordance with EN 50274
- Ensure that suitable ESD protective measures are also taken during mounting. Otherwise the FLEXBUS+ backplane bus may be damaged.
- Take suitable measures to ensure that foreign matter does not enter the connector openings, in particular that of the memory plug.

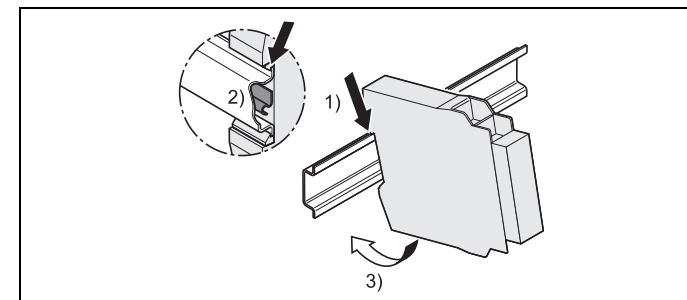

- ⇒ Make sure that the voltage supply of the MELSEC-WS safety controller is switched off.

- ⇒ Hang the device onto the DIN rail (1).

- ⇒ Ensure that the earthing spring contact is positioned correctly (2)). The earthing spring contact of the module must contact the DIN rail securely to allow electrical conductivity.

- ⇒ Snap the module onto the DIN rail by pressing it lightly in the direction of the arrow (3).

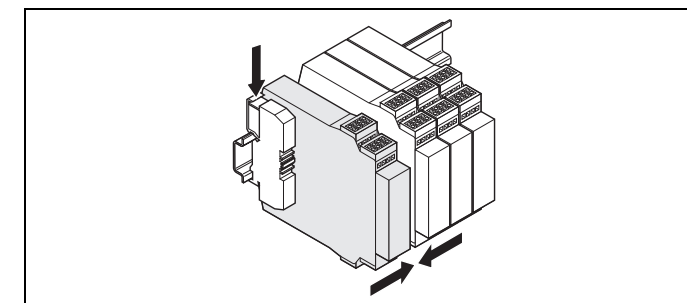

- ⇒ If there are several modules, slide the modules together individually in the direction of the arrow until the side plug connection latches in.

- ⇒ Install the end clips on the left and right.

## 5.2 Steps for dismantling the modules

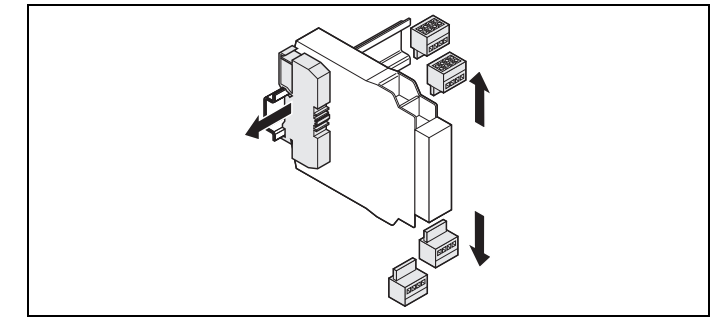

- ⇒ Remove the removable terminals with wiring and the end clips.

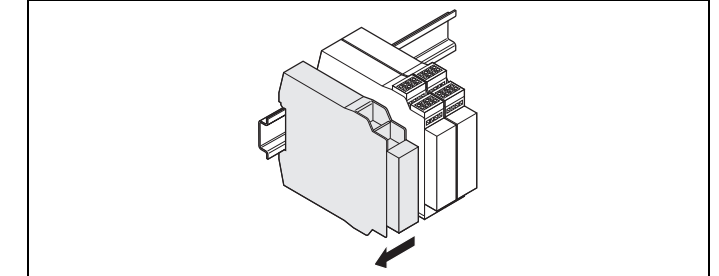

- ⇒ If there are several modules, slide the modules away from each other individually in the direction of the arrow until the side plug connection is separated.

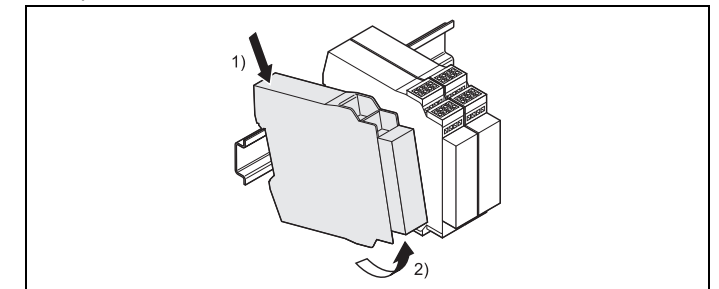

- ⇒ Press the module downwards at the rear (1) and remove it from the DIN rail in the direction of the arrow while keeping it pressed down (2).

## 6 Electrical installation



### De-energize the entire system!

#### Mettez le système entièrement hors tension!

The system could start up unexpectedly while you are connecting the devices.

*Le système pourrait être mis en marche par inadvertance pendant qu'on connecte les dispositifs.*

### Observe the relevant safety standards!

#### Observez les normes de sécurité pertinentes!

All safety related parts of the installation (cabling, connected sensors and actuators, configuration settings, EDM) must be according to the relevant safety standards (e.g. IEC 62061 or EN/ISO 13849-1).

*Tout matériel ou logiciel ayant des implications de sécurité (câblage, capteurs et actionneurs à raccorder, paramétrages de configuration, EDM) doivent être conformes aux normes de sécurité applicables (par exemple, IEC 62061 ou EN/ISO 13849-1).*

This requirement can mean that safety-related signals must be of redundant design, or that single-channel signal cables must be laid with protection, or they must be protected against short circuits by using test outputs and/or regular function tests.

⇒ Note that short circuits between test outputs and the related input cannot be detected.

⇒ Consider laying these signals with protection or laying them separately.

*Cette exigence peut amener à adopter une conception redondante pour les signaux ayant trait à la sécurité, ou à installer les câbles des signaux uniques sous protection ou en protégeant ces câbles contre les court-circuits au moyen de sorties-tests et/ou de tests fonctionnels réguliers.*

⇒ On notera que les court-circuits entre sorties-tests et entrées correspondantes restent indétectables.

⇒ Prévoir l'installation de ces signaux sous protection ou les faire cheminer séparément.

- The MELSEC-WS safety controller fulfils the EMC requirements in accordance with the basic specification IEC 61000-6-2 for industrial use.
- Electrical installation in accordance with IEC 60204-1
- To ensure full electromagnetic compatibility (EMC), the DIN rail has to be connected to functional earth (FE).
- The voltage supply of the devices must be capable of buffering brief mains voltage failures of 20ms as specified in IEC 60204-1.
- The voltage supply as well as all signals connected have to fulfil the regulations for extra-low voltages with safe separation (SELV, PELV) in accordance with IEC 60664 and EN 50178 (equipment of electrical power installation with electronic devices)
- You must to connect all the modules of the MELSEC-WS safety controller, the connected protective devices as well as the voltage supply/ies with the same 0VDC (GND).
- All connected pick-ups and downstream controllers as well as wiring and installation have to fulfil the required safety characteristics.
- Depending on the external loads, especially for inductive loads, additional external protective elements, e.g. varistors or RC elements may be necessary in order to protect the safe outputs. Take into account that the response times may increase, depending on the type of protective element.
- If a module is replaced the correct terminal assignment has to be guaranteed, for example by labelling or suitable cable routing.
- For further information that is to be taken into consideration when the MELSEC-WS safety controller is used refer to the "Safety Controller User's Manual" and "Safety Controller Setting and Monitoring Tool Operating Manual".

## 7 Configuration and commissioning



### Do not commission without a check by qualified safety personnel!

#### Ne pas procéder à la mise en service sans qu'un personnel de sécurité qualifié ait effectué un contrôle!

Before initial commissioning of a system using a MELSEC-WS safety controller, it must be checked and released by qualified safety personnel. Document the result of the safety check.

*La première mise en service d'un système utilisant un contrôleur de sécurité MELSEC-WS ne doit être effectuée qu'après contrôle et sur autorisation délivrée par un personnel qualifié. Les résultats du contrôle de sécurité doivent être dûment documentés et suivis.*

The MELSEC-WS safety controller can be configured by the Setting and Monitoring Tool connected to the RS-232 interface or USB interface (only WS0-CPU3 module) of a CPU module, or the port of an Ethernet interface module.

- Note
- The Setting and Monitoring Tool is required to configure and commission the MELSEC-WS safety controller.
  - The system configuration of the complete MELSEC-WS safety controller is stored in the memory plug. The system does not have to be reconfigured when a module is replaced.
  - For the diagnostics after module replacement with the higher version (for instance, upgraded from V1.11.0 to V2.01.0), the Setting and Monitoring Tool version 1.7.0 is required.

## 8 Technical data

### 8.1 Technical data WS0-XTIO

#### Safety-related parameters

This information relates to an ambient temperature of +40°C, which is normally used for the statistical calculation of the values.

Safety Integrity Level	SIL3 (IEC 61508)
SIL claim limit	SIL CL3 (IEC 62061)
Category* <sup>1</sup>	
For single channel outputs with test pulses enabled for all safe outputs (Q1...Q4)	Category 4 (EN/ISO 13849-1)
For single channel outputs with test pulses disabled for this or any other safe output (Q1...Q4)	Category 3 (EN/ISO 13849-1)
For dual channel outputs with or without test pulses disabled for this or any other safe output (Q1...Q4)	Category 4 (EN/ISO 13849-1)
Performance Level	PL e (EN/ISO 13849-1)
PFHd* <sup>1</sup>	
For single channel outputs	4.8×10 <sup>-9</sup>
For dual channel outputs	0.9×10 <sup>-9</sup>
T <sub>M</sub> (mission time)	20 years (EN/ISO 13849)* <sup>2</sup>

### General data

Protection class	III (IEC 61140)
Enclosure rating	IP 20 (IEC 60529)
Ambient temperature in operation	-25 ... +55 °C
Storage temperature	-25 ... +70 °C
Humidity	10 ... 95 %, non-condensing
Climatic conditions	55 °C, 95 % relative humidity (IEC 61131-2), No corrosive gases
Vibration resistance	5-150Hz/1g (IEC 60068-2-6) 10-500Hz/3gRMS (IEC 60068-2-64)
Shock resistance	
Continuous shock	10 g, 16 ms (IEC 60068-2-27)
Single shock	30 g, 11 ms (IEC 60068-2-27)
Electromagnetic compatibility	Class A (IEC 61000-6-2, EN 55011)
System connection	Dual level spring clamp terminals
Power input via FLEXBUS+ without currents to X1, X2	Max. 2.2 W
Cross-section of connecting wires	Single-core or finely stranded: 0.2 ... 1.5 mm <sup>2</sup> (24 to 15 AWG) Finely stranded with ferrules: 0.25 ... 1.5 mm <sup>2</sup> (23 to 15 AWG)
Data interface	Backplane bus (FLEXBUS+)
Dimensions (W × H × D)	22.5mm × 106.5mm × 120.6mm
Weight	164g (±5 %)

\*1 Applies for single channel inputs and for dual channel inputs.

\*2 If safe outputs are used without test pulses, at least once per year either all safe outputs without test pulses have to be switched off at the same time for at least 1 second or alternatively a power reset has to be performed.

### Power supply unit (A1, A2)

Supply voltage	24VDC (16.8VDC ... 30VDC)
Supply voltage UL/GSA applications	24VDC
Type of supply voltage	PELV or SELV The current of the power supply unit for the module has to be limited to a maximum of 4A either by the power supply unit itself or by a fuse.
Power consumption	Max. 120 W (30 V × 4 A), determined by the load at the outputs Q1 to Q4, plus max. 1 W power input for the internal circuit
Switch-on time	Max. 18 s
Short-circuit protection	4 A gG (with tripping characteristic B or C)

### Safe inputs (I1 ... I8)

Input voltage High	13 ... 30VDC
Input voltage Low	-5 ... +5VDC
Input current High	2.4 ... 3.8 mA
Input current Low	-2.5 ... 2.1 mA
Input reverse current in case of ground interruption* <sup>3</sup>	
Hardware version < V1.0x	Max. 20 mA 1.5 kΩ effective reverse resistance to power supply
Hardware version ≥ V1.10	Max. 2 mA
Switching current (with mechanical contacts)	14.4 mA at 5 V 3 mA at 24 V
Input pulse filtering (pulses within these limits have no effect)	
Pulse width	Max. 0.9 ms
Pulse period	Min. 4 ms
Input capacitance	Max. 10 nF + 10 %
Discrepancy times	4 ms ... 30 s, configurable
Number of inputs	8

\*3 Do not switch other safe inputs in parallel if the reverse current could lead to a High state at the other input.

### Test outputs (X1, X2)

Number of outputs	2 (with 2 test pulse generators)
Output type	PNP semiconductor, short-circuit protected, shortcircuit monitoring (selectable)
Output voltage High	15 ... 30VDC (max. 1.8 V drop to terminal A1 of main module)
Output resistance Low	≤33 Ω + 10 %, current limited at approx. 10 mA
Output current	Max. 120 mA at each test output (X1 or X2) This means that a maximum of 8 testable sensor cascades per module with max. 30 mA each are possible. The total current for the MELSEC-WS safety controller for all test outputs is limited to a maximum of 1.28 A. This corresponds to e.g. a maximum of 32 testable sensor cascades with 30 mA each plus 64 tactile sensors on inputs on safety I/O modules with 5 mA each.
Test pulse rate (test period)	1 ... 25 Hz, configurable
Test pulse duration (test gap)	1 ... 100 ms, configurable
Load capacity	1 μF for test gap ≥ 4 ms 0.5 μF for test gap 1 ms
Cable resistance	≤ 100 Ω

Safe outputs (Q1 ... Q4)	
Number of outputs	4
Output type	PNP semiconductor, short-circuit protected, shortcircuit monitoring (selectable)
Output voltage High	16 ... 30VDC (max. 0.8 V drop to terminal A1 of this module)
Leakage current Low	
Normal operation	Max. 0.1mA
Fault case*4	
Hardware version < V1.0x	Max. 1.6 mA
Hardware version ≥ V1.10	Max. 2.0 mA
Output current	Max. 2.0 A
Total current I <sub>sum</sub>	
T <sub>A</sub> ≤ 45 °C	Max. 4.0 A
T <sub>A</sub> ≤ 55 °C	Max. 3.2 A
For UL/CSA applications	Max. 3.2 A
Test pulse width*5	< 650µs or disabled*6*7
Test pulse rate	Max. 5 Hz
Capacitive load	≤ 0.5 µF
Cable resistance*8	Max. 5 Ω (e.g. 100 m × 1.5 mm <sup>2</sup> = 1.2 Ω)
Max. permitted coil energy without external protection elements*9	
Hardware version V1.00	0.22J
Hardware version ≥ V1.01	0.37J
Response time	Depending on the logic configuration (See the Safety Controller User's Manual)
Maximum ON time at internal hardware error	10ms/50ms (See the Safety Controller User's Manual)
Data interface	Backplane bus (FLEXBUS+)

\*4 In the case of a fault (0 V cable open circuit) with a load resistance of min. 2.5 kΩ, maximally the leakage current flows from the safe output. For smaller load resistors the leakage current may be greater but in this case the output voltage will be < 5 V. The connected device, e.g. relay or fail-safe programmable controller) must detect this status as Low.

\*5 When active, the outputs are tested cyclically (brief switching to Low). When selecting the downstream controllers, make sure that the test pulses do not result in deactivation when using the above parameters or disable the test pulses on the outputs.

\*6 If safe outputs are used without test pulses, at least once per year either all safe outputs without test pulses have to be switched off at the same time for at least 1 second or alternatively a power reset has to be performed.

\*7 If safe outputs are used without test pulses: Use protected or separate cabling for the safe outputs without test pulses, because a short circuit to 24 V cannot be detected if the safe output is High. This could inhibit the switch-off capability for the other safe outputs in case of an internal detected hardware failure due to reverse powering.

\*8 Make sure to limit the individual line core resistance to the downstream controller to this value to ensure that a short-circuit between the outputs is safely detected. (Also note IEC 60204 Electrical Machine Equipment, Part 1: General Requirements.)

\*9 Examples for resulting max. coil inductivity:  
HW V1.00.0: 1760 mH @ 0.5A, 440 mH @ 1A, 110 mH @ 2A  
HW V1.01.0: 2960 mH @ 0.5A, 740 mH @ 1A, 185 mH @ 2A  
If an inductive load (such as a contactor, relay, and valve) does not exceed the maximum coil energy, external protection elements are not required.

Do not connect a RC element in parallel with an inductive load. Doing so creates a resonance circuit in positive voltage area after the applied voltage is decreased, causing overshoot and resulting in short circuit.

The allowed time for overshoot is as follows:

Firmware version V2.10 or lower: 1ms or less

Firmware version V2.11: 3ms or less

Firmware version V3.10 or higher: 3ms or less; or when the high capacity load switch is enabled, 43ms or less

Overshoot can be reduced by connecting resistances in parallel.

## 8.2 Technical data WS0-XTDI

### Safety-related parameters

This information relates to an ambient temperature of +40°C, which is normally used for the statistical calculation of the values.

Safety Integrity Level	SIL3 (IEC 61508)
SIL claim limit	SIL CL3 (IEC 62061)
Category	Category 4 (EN/ISO 13849-1)
Performance Level	PLe (EN/ISO 13849-1)
PFHd	0.4 × 10 <sup>-9</sup>
T <sub>M</sub> (mission time)	20 years (EN/ISO 13849)

### General data

Protection class	III (IEC 61140)
Enclosure rating	IP20 (IEC 60529)
Ambient temperature in operation	-25 ... +55 °C
Storage temperature	-25 ... +70 °C
Humidity	10 ... 95 %, non-condensing
Climatic conditions	55 °C, 95 % relative humidity (IEC 61131-2), No corrosive gases
Vibration resistance	5-150Hz/1g (IEC 60068-2-6) 10-500Hz/3gRMS (IEC 60068-2-64)
Shock resistance	
Continuous shock	10 g, 16 ms (IEC 60068-2-27)
Single shock	30 g, 11 ms (IEC 60068-2-27)
Electromagnetic compatibility	Class A (IEC 61000-6-2, EN 55011)
System connection	Dual level spring clamp terminals
Power input via FLEXBUS+ without currents to X1 ... X8	Max. 2 W
Cross-section of connecting wires	Single-core or finely stranded: 0.2 ... 1.5 mm <sup>2</sup> (24 to 15 AWG) Finely stranded with ferrules: 0.25 ... 1.5 mm <sup>2</sup> (23 to 15 AWG)
Dimensions (W × H × D)	22.5mm × 106.5mm × 120.6mm
Weight	139g (±5 %)

### Safe inputs (I1 ... I8)

Input voltage High	13 ... 30VDC
Input voltage Low	-5 ... +5VDC
Input current High	2.4 ... 3.8 mA
Input current Low	-2.5 ... 2.1 mA
Input reverse current in case of ground interruption*1	
Hardware version < V1.0x	Max. 20 mA 1.5 kΩ effective reverse resistance to power supply
Hardware version ≥ V1.10	Max. 2 mA
Switching current (with mechanical contacts)	14.4 mA at 5 V 3 mA at 24 V
Input capacitance	Max. 10 nF + 10 %
Discrepancy times	4 ms ... 30 s, configurable
Number of inputs	8

### Test outputs (X1 ... X8)

Number of outputs	8 (with 2 test pulse generators)
Output type	PNP semiconductor, short-circuit protected, crosscircuit monitoring
Output voltage	15 ... 30VDC (max. 1.8 V drop to terminal A1 of CPU module)
Output resistance Low	≤33 Ω + 10 %, current limited at approx. 10 mA
Output current	Max. 120 mA at each of the two test signal generators (X1/X3/X5/X7 or X2/X4/X6/X8) This means that a maximum of 8 testable sensor cascades per module with max. 30 mA each are possible. The total current for the MELSEC-WS safety controller for all test outputs is limited to a maximum of 1.28 A. This corresponds to e.g. a maximum of 32 testable sensor cascades with 30 mA each plus 64 tactile sensors on inputs on safety I/O modules with 5 mA each.
Test pulse rate (test period)	1 ... 25 Hz, configurable
Test pulse duration (test gap)	1 ... 100 ms, configurable
Load capacity	1 µF for test gap ≥ 4 ms 0.5 µF for test gap 1 ms
Cable resistance	≤ 100 Ω

\*1 Do not switch other safety inputs in parallel if the reverse current could lead to a High state at the other input.

Country/Region	Sales office/Tel
USA	Mitsubishi Electric Automation Inc. 500 Corporate Woods Parkway, Vernon Hills, IL 60061, USA Tel : +1-847-478-2100
Brazil	MELCO-TEC Representacao Comercial e Assessoria Tecnica Ltda. Av. Paulista, 1439, cj74, Beta Vista, Sao Paulo CEP: 01311-200-SP Brazil Tel : +55-11-3146-2200
Germany	Mitsubishi Electric Europe B.V. German Branch Gothaer Strasse 8, D-40880 Ratingen, Germany Tel : +49-2102-486-0
UK	Mitsubishi Electric Europe B.V. UK Branch Travellers Lane, Hatfield, Hertfordshire, AL10 8XB, UK. Tel : +44-1707-27-6100
Italy	Mitsubishi Electric Europe B.V. Italian Branch Viale Colleoni 7-20864 Agrate Brianza (Milano), Italy Tel : +39-039-60531
Spain	Mitsubishi Electric Europe B.V. Spanish Branch Carretera de Rubi 76-80.AC.420, E-08190 Sant Cugat del Valles (Barcelona), Spain Tel : +34-93-565-3131
France	Mitsubishi Electric Europe B.V. French Branch 25, Boulevard des Bouvets, F-92741 Nanterre Cedex, France Tel : +33-1-5568-5568
Czech Republic	Mitsubishi Electric Europe B.V.-o.s.Czech office Avenir Business Park, Radicka 751/113e, 158 00 Praha5, Czech Republic Tel : +420-251-551-470
Poland	Mitsubishi Electric Europe B.V. Polish Branch ul. Krakowska 50, 32-083 Balice, Poland Tel : +48-12-630-47-00
Russia	Mitsubishi Electric Europe B.V. Russian Branch St.Petersburg office Piskarevsky pr. 2, bld 2, lit "Sch", BC "Benua", office 720: 195027, St. Petersburg, Russia Tel : +7-812-633-3497
South Africa	CBI-Electric, Private Bag 2016, ZA-1600 Isando, South Africa Tel : +27-11-977-0770
China	Mitsubishi Electric Automation (China) Ltd. No.1386 Hongqiao Road, Mitsubishi Electric Automation Center, Changning District, Shanghai, China Tel : +86-21-2322-3030
Taiwan	Setsuyo Enterprise Co., Ltd. 6F., No.105, Wugong 3rd Road, Wugong District, New Taipei City 24889, Taiwan, R.O.C. Tel : +886-2-2299-2499
Korea	Mitsubishi Electric Automation Korea Co., Ltd. 3F, 1480-6, Gayang-Dong, Gangseo-Gu, Seoul, 157-200, Korea Tel : +82-2-3660-9530
Singapore	Mitsubishi Electric Asia Pte. Ltd. Industrial Division 307, Alexandra Road, Mitsubishi Electric Building, Singapore, 159943 Tel : +65-6470-2308
Thailand	Mitsubishi Electric Automation (Thailand) Co., Ltd. Bang-Chan Industrial Estate No.111 Soi Serithai 54, T.Kannayao, A.Kannayao, Bangkok 10230 Thailand Tel : +66-2906-3238
Indonesia	P. T. Autoteknindo Sumber Makmur Muara Karang Selatan, Block A / Utara No.1 Kav. No. 11, Kawasan Industri Pergudangan, Jakarta-Utara 14440, P.O. Box 5045, Indonesia Tel : +62-21-663-0833
India	Mitsubishi Electric India Pvt. Ltd. 2nd Floor, Tower A & B, Cyber Greens, DLF Cyber City, DLF Phase-III, Gurgaon-122002 Haryana, India Tel : +91-124-463-0300
Australia	Mitsubishi Electric Australia Pty. Ltd. 348 Victoria Road PO BOX11, Rydalmere, N.S.W 2116, Australia Tel : +61-2-9684-7777

## MITSUBISHI ELECTRIC CORPORATION

HEAD OFFICE : TOKYO BUILDING, 2-7-3 MARUNOUCHI, CHIYODA-KU, TOKYO 100-8310, JAPAN  
NAGOYA WORKS : 1-14, YADA-MINAMI 5-CHOME, HIGASHI-KU, NAGOYA, JAPAN

When exported from Japan, this manual does not require application to the Ministry of Economy, Trade and Industry for service transaction permission.

Specifications subject to change without notice.

**SICK** SICK AG <http://www.sick.com/>