

CL2Y16-TP1M1V

CC-Link/LT Remote I/O Module

Thank you very much for purchasing this product.

Please read this manual thoroughly before starting to use the product and handle the product properly.

User's Manual

MODEL	CL2Y16-TP1M1V-U
MODEL CODE	13JP08
IB(NA)-0800238-C(1406)MEE	

© 2002 MITSUBISHI ELECTRIC CORPORATION

SAFETY PRECAUTIONS

(Read these precautions before using.) Please read this manual carefully and pay special attention to safety in order to handle this product properly. Also pay careful attention to safety and handle the module properly.

These precautions apply only to Mitsubishi equipment. Refer to the user's manual of the CPU module to use for a description of the programmable controller system safety precautions.

In this manual, the safety precautions are classified into two levels: "▲ WARNING" and "▲ CAUTION".

▲ WARNING Indicates that incorrect handling may cause hazardous conditions, resulting in death or severe injury.

▲ CAUTION Indicates that incorrect handling may cause hazardous conditions, resulting in minor or moderate injury or property damage.

Under some circumstances, failure to observe the precautions given under "▲ CAUTION" may lead to serious consequences. Observe the precautions of both levels because they are important for personal and system safety. Make sure that the end users read this manual and then keep the manual in a safe place for future reference.

[DESIGN PRECAUTIONS]

- ▲ WARNING**
 - Refer to Chapter 3 of this manual for the operation status of the module in case a communication error occurs in the data link.
 - Output could be switched on or off when a problem occurs in the remote I/O modules.
- So build an external monitoring circuit that will monitor any output signals that could cause a serious accident.

[DESIGN PRECAUTIONS]

- ▲ CAUTION**
 - Do not have control cables and communication cables bundled with or placed near by the main circuit and/or power cables. Wire those cables at least 100mm (3.94 inch) away from the main circuit and/or power cables. It may cause malfunction due to noise interference.

[INSTALLATION PRECAUTIONS]

- ▲ CAUTION**
 - Use the module in an environment that meets the general specifications contained in this manual. Using this module in an environment outside the range of the general specifications could result in electric shock, fire, erroneous operation, and damage to or deterioration of the product.
 - Do not directly touch the module's conductive parts. Doing so could cause malfunction or trouble in the module.
 - Securely fix the module in place using the DIN rail.
 - If the module is not securely fixed, it may fall off or cause malfunction.

[WIRING PRECAUTIONS]

- ▲ WARNING**
 - Perform installation and wiring after disconnecting the power supply at all phases externally. If the power is not disconnected at all phases an electric shock or product damage may result.

[WIRING PRECAUTIONS]

- ▲ CAUTION**
 - Wire the module correctly upon verifying the product's rated voltage and the connector pin arrangement. Connecting to a power supply different from rating or miss-wiring may cause fire and/or product failure.
 - Make sure foreign objects do not get inside the module, such as dirt and wire chips. It may cause fire, product failure or malfunction.

[STARTING AND MAINTENANCE PRECAUTIONS]

- ▲ WARNING**
 - Before cleaning the module, be sure to shut off all the phases of the power supply externally.
 - Failure to do so may cause failure or malfunction of the modules.

[STARTING AND MAINTENANCE PRECAUTIONS]

- ▲ CAUTION**
 - Do not disassemble or modify the module. Doing so may cause failure, malfunction, injury, or fire.
 - The module case is made of resin; do not drop it or subject it to strong shock. A module damage may result.
 - Make sure to switch all phases of the external power supply off before installing or removing the module to/from the panel. Failure to do so may cause failure or malfunction of the modules.

[DISPOSAL PRECAUTIONS]

- ▲ CAUTION**
 - When disposing of this product, treat it as industrial waste.

PRÉCAUTIONS DE SÉCURITÉ

(Lire ces précautions avant usage.) Prière de lire attentivement ce manuel. Prêter une attention particulière à tout ce qui a trait à la sécurité pour utiliser le produit correctement.

Ces précautions ne concernent que l'équipement Mitsubishi. Dans le manuel de l'utilisateur du module CPU correspondant, voir l'exposé des précautions de sécurité concernant le système de l'automate programmable. Dans ce manuel, les précautions de sécurité sont classées en deux niveaux, à savoir : "▲ AVERTISSEMENT" et "▲ ATTENTION".

▲ AVERTISSEMENT Attire l'attention sur le fait qu'une négligence peut créer une situation de danger avec risque de mort ou de blessures graves.

▲ ATTENTION Attire l'attention sur le fait qu'une négligence peut créer une situation de danger avec risque de blessures légères ou de gravité moyennes ou risque de dégâts matériels.

Dans certaines circonstances, le non-respect d'une précaution de sécurité introduite sous le titre "▲ ATTENTION" peut avoir des conséquences graves. Les précautions de ces deux niveaux doivent être observées dans leur intégralité car elles ont trait à la sécurité des personnes et aussi du système. Veiller à ce que les utilisateurs finaux lisent ce manuel qui doit être conservé soigneusement à portée de main pour s'y référer autant que de besoin.

[PRÉCAUTIONS DE CONCEPTION]

- ▲ AVERTISSEMENT**
 - Pour l'état opérationnel du module en cas d'erreur de communication dans la liaison de données, se reporter au Chapitre 3 du présent manuel.
 - La sortie pourrait se trouver activée ou désactivée à la survenance d'un problème dans le module E/S distant.
- On constituera donc un circuit de surveillance externe couvrant tous les signaux de sortie qui pourraient être à l'origine d'un accident grave.

[PRÉCAUTIONS DE CONCEPTION]

- ▲ ATTENTION**
 - Ne pas grouper ni placer à proximité les câbles de commande ou câbles de communication avec les câbles des circuits principaux et/ou d'alimentation. Câbler en plaçant ces câbles à une distance d'au moins 100mm (3,94 pouces) des câbles des circuits principaux ou de l'alimentation. Cela pourrait être à l'origine d'un bruit parasite entraînant des dysfonctionnements.

[PRÉCAUTIONS D'INSTALLATION]

- ▲ ATTENTION**
 - Utiliser le module dans un environnement conforme aux spécifications générales présentées dans ce manuel. L'utilisation de ce module dans un environnement autre que celui prévu dans les spécifications générales peut être à l'origine d'un choc électrique, d'un départ de feu ou d'un dysfonctionnement, ou peut endommager ou détériorer le produit.
 - Éviter tout contact direct avec les parties conductrices du module. Cela pourrait être à l'origine de dysfonctionnements ou autres problèmes avec le module.
 - Fixer fermement le module en place sur le rail DIN. Si le module n'est pas fermement fixé, il risque de tomber ou il peut y avoir des dysfonctionnements.

[PRÉCAUTIONS DE CÂBLAGE]

- ▲ AVERTISSEMENT**
 - Effectuer l'installation et le câblage après avoir déconnecté l'alimentation externe sur toutes les phases. Si l'alimentation n'a pas été coupée sur toutes les phases, il y a un risque d'électrocution ou d'endommagement du produit.

[PRÉCAUTIONS DE CÂBLAGE]

- ▲ ATTENTION**
 - Câbler le module correctement après vérification de la tension nominale du produit et de l'efficacité des broches de connecteur.
 - Le raccordement d'une alimentation de tension nominale différente ou une erreur de câblage peuvent être à l'origine d'un départ de feu et/ou d'une panne du produit.
 - Veiller à éviter toute pénétration d'impuretés, copeaux de câblage ou autre corps étranger dans le module. Cela pourrait être à l'origine d'un départ de feu, ou du panne ou d'un dysfonctionnement du produit.

[PRÉCAUTIONS DE DÉMARRAGE ET DE MAINTENANCE]

- ▲ AVERTISSEMENT**
 - Avant de nettoyer le module, vérifier sur l'alimentation externe a bien été coupée sur toutes les phases.
 - Faute de quoi, il y a un risque de panne ou de dysfonctionnement des modules.

[PRÉCAUTIONS DE DÉMARRAGE ET DE MAINTENANCE]

- ▲ ATTENTION**
 - Ne pas démonter ni modifier le module. Cela pourrait être à l'origine de pannes, de dysfonctionnements, de blessures ou d'un départ de feu.
 - Ne pas faire tomber ou soumettre le module à des chocs car son boîtier en plastique est fragile. Il pourrait en résulter un endommagement du module.
 - Avant d'installer le module dans le tableau ou de l'en retirer, il est indispensable de couper l'alimentation externe sur toutes les phases. Faute de quoi, il y a un risque de panne ou de dysfonctionnement des modules.

[PRÉCAUTIONS DE MISE AU REBUT]

- ▲ ATTENTION**
 - Lors de sa mise au rebut, ce produit doit être traité comme un déchet industriel.

CONDITIONS OF USE FOR THE PRODUCT

- Mitsubishi programmable controller ("the PRODUCT") shall be used in conditions:
 - where any problem, fault or failure occurring in the PRODUCT, if any, shall not lead to any major or serious accident; and
 - where the backup and fail-safe function are systematically or automatically provided outside of the PRODUCT for the case of any problem, fault or failure occurring in the PRODUCT.
 - The PRODUCT has been designed and manufactured for the purpose of being used in general industries. MITSUBISHI SHALL HAVE NO RESPONSIBILITY OR LIABILITY (INCLUDING, BUT NOT LIMITED TO ANY AND ALL RESPONSIBILITY OR LIABILITY BASED ON CONTRACT, WARRANTY, TORT, PRODUCT LIABILITY) FOR ANY INJURY OR DEATH TO PERSONS OR LOSS OR DAMAGE TO PROPERTY CAUSED BY THE PRODUCT THAT ARE OPERATED OR USED IN APPLICATION NOT INTENDED OR EXCLUDED BY INSTRUCTIONS, PRECAUTIONS, OR WARNING CONTAINED IN MITSUBISHI'S USER, INSTRUCTION AND/OR SAFETY MANUALS, TECHNICAL BULLETINS AND GUIDELINES FOR THE PRODUCT. ("Prohibited Application")
- Prohibited Applications include, but not limited to, the use of the PRODUCT in:
- Nuclear Power Plants and any other power plants operated by Power companies, and/or any other cases in which the public could be affected if any problem or fault occurs in the PRODUCT.
 - Railway companies or Public service purposes, and/or any other cases in which establishment of a special quality assurance system is required by the Purchaser or End User.
 - Aircraft or Aerospace, Medical applications, Train equipment, transport equipment such as Elevator and Escalator, Incineration and Fuel devices, Vehicles, Manned transportation, Equipment for Recreation and Amusement, and Safety devices, handling of Nuclear or Hazardous Materials or Chemicals, Mining and Drilling, and/or other applications where there is a significant risk of injury to the public or property.
- Notwithstanding the above, restrictions Mitsubishi may in its sole discretion, authorize use of the PRODUCT in one or more of the Prohibited Applications, provided that the usage of the PRODUCT is limited only for the specific applications agreed to by Mitsubishi and provided further that no special quality assurance or fail-safe, redundant or other safety features which exceed the general specifications of the PRODUCTS are required. For details, please contact the Mitsubishi representative in your region.

1. Overview

This user's manual explains specifications and names of individual parts of the CL2Y16-TP1M1V type CC-Link/LT remote I/O module (hereinafter abbreviated as remote I/O module).

2. Specifications

2.1 General Specifications

The General specifications for the remote I/O module are shown in the following table.

Item	Specification
Operating ambient temperature	0 to 55°C 0 à 55 °C
Operating ambient humidity	5 to 95%RH, non-condensing
Storage ambient temperature	-25 to 75°C
Vibration resistance	Compliant with JIS B 3502 and IEC 61131-2
Shock resistance	Compliant with JIS B 3502 and IEC 61131-2 (147 m/s ² , 3 times each in 3 directions X, Y, Z)
Operating atmosphere	No corrosive gases
Operating altitude	0 to 2000m
Installation location	Inside a control panel ¹⁾
Overvoltage category	II or less
Pollution degree	2 or less

¹⁾ This indicates the section of the power supply to which the equipment is assumed to be connected between the public electrical power distribution network and the machinery within premises. Category II applies to equipment for which electrical power is supplied from fixed facilities. The surge voltage withstand level for up to the rated voltage of 300V is 2500V.

²⁾ This index indicates the degree to which conductive material is generated in terms of the environment in which the equipment is used. Pollution level 2 is when only non-conductive pollution occurs. A temporary conductivity caused by condensing must be expected occasionally.

³⁾ It can also be used in an environment other than on the control panel if the conditions such as usage ambient temperature and humidity are satisfied.

2.2 Performance specifications

The performance specifications for the remote I/O module are shown in the following table.

Item	Type	CL2Y16-TP1M1V
Number of outputs		16 points
Isolation method		Photocoupler isolation
Rated load voltage		12/24V DC
Operating load voltage range		10.2 to 28.8V DC (ripple ratio: within 5%)
Max. load current		0.1A/point 1.6A† common
Max. inrush current		0.7A 10ms or lower
Leakage current at OFF		0.1mA or lower
Voltage drop at ON		0.3V or lower (TYP.) 0.1A, 0.6V or lower (MAX.) 0.1A
Output method		Sink type
Protect function		Overload protection function / Overheat protection function
Response time	OFF→ON	0.5ms or lower
	ON→OFF	0.5ms or lower (Resistive load)
Surge suppression		Zener diode
Common wiring method		16 points/1 common (MIL connector 1-wire type)
Number of stations occupied		In 4-point mode: Occupies 4 stations, In 8-point mode: Occupies 2 stations, In 16-point mode: Occupies 1 station

Item	Type	CL2Y16-TP1M1V
External power supply of the output part	Voltage	10.2 to 28.8V DC (ripple ratio : within 5%)
	Current consumption	15mA or lower (When 24V DC and all point is on) Not including external load current
Module power supply	Voltage	20.4 to 28.8V DC (ripple ratio : within 5%)
	Current consumption	50mA or lower (When 24V DC and all point is on)
Noise durability		DC type noise voltage 500Vp-p, noise width 1µs, noise carrier frequency 25 to 60Hz (noise simulator condition) First transient/noise burst IEC 61000-4-4 : 1kV
Withstand voltage		500V AC for 1 minute between primary (external DC terminal) and secondary (internal circuit)
Insulation resistance		10MΩ or more between primary (external DC terminal) and secondary (internal circuit) when measured with a 500V DC insulation resistance tester
Protection class		IP2X
Weight		0.05kg
I/O part connection method		20 pin MIL connector
Module installation method		DIN rail installation, Can be installed in six directions

3. Part Names

This section explains the names of the components for the remote I/O module.

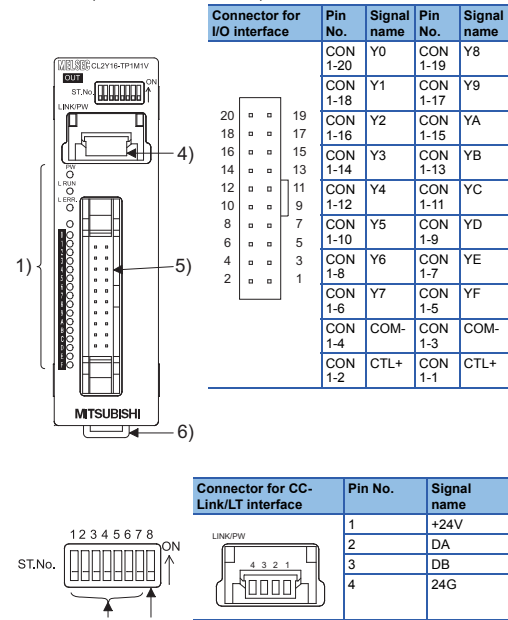

Connecteur pour interface E/S	Broch e N°	Nom de signal	Broch e N°	Nom de signal
	CON 1-20	Y0	CON 1-19	Y8
	CON 1-18	Y1	CON 1-17	Y9
	CON 1-16	Y2	CON 1-15	YA
	CON 1-14	Y3	CON 1-13	YB
	CON 1-12	Y4	CON 1-11	YC
	CON 1-10	Y5	CON 1-9	YD
	CON 1-8	Y6	CON 1-7	YE
	CON 1-6	Y7	CON 1-5	YF
	CON 1-4	COM-	CON 1-3	COM-
	CON 1-2	CTL+	CON 1-1	CTL+

Connecteur pour interface CC-Link/LT	Broche N°	Nom de signal
	1	+24V
	2	DA
	3	DB
	4	24G

No. Item	Description																								
1)	Operating status indicator LEDs LED name Confirmation details PW On: Power supply on. Off: The power supply is turned off or the voltage drop is too large. L RUN On: Normal communication. Off: Communication cutoff (time expiration error). L ERR. On: Indicates that a communication data error has occurred or the setting switch is outside the allowable range. Flicker at regular intervals: Indicates that the setting switch has been changed while current is being conducted. (The module continues to operate even while the LED is flickering. The changed settings will be reflected when the power has been restored.) Flicker at irregular intervals: Indicates that the terminal resistor is left unconnected or that the module or connection cable are affected by noise. Off: Normal communication. 0 to F Displays the ON/OFF status of the output (turned on in the ON status and turned off in the OFF status).																								
2)	Output hold setting ₁ switch (SW8) The switch is set to OFF at shipment from the factory. ON: Maintain output OFF: Turn output off																								
3)	Station number setting switches ₁ (SW1 to 7) Select "10", "20" or "40" to set the ten's place of the station number. Select "1", "2", "4" or "8" to set the one's place of the station number. All switches are set to OFF at shipment from the factory. Always set the station number within the range of 1 to 64. A setting error occurs and "L ERR." LED flickers if the value outside the range 1 to 64 is set. (Example) Set the switches as below when setting the station number to 32: <table border="1"> <thead> <tr> <th>Station number</th> <th>Ten's place</th> <th>One's place</th> </tr> </thead> <tbody> <tr> <td>40</td> <td>20 (SW1)</td> <td>10 (SW2)</td> </tr> <tr> <td>20</td> <td>10 (SW2)</td> <td>8 (SW3)</td> </tr> <tr> <td>10</td> <td>8 (SW3)</td> <td>4 (SW4)</td> </tr> <tr> <td>8</td> <td>4 (SW4)</td> <td>2 (SW5)</td> </tr> <tr> <td>4</td> <td>2 (SW5)</td> <td>1 (SW6)</td> </tr> <tr> <td>2</td> <td>1 (SW6)</td> <td>OFF (SW7)</td> </tr> <tr> <td>1</td> <td>OFF (SW7)</td> <td>OFF</td> </tr> </tbody> </table>	Station number	Ten's place	One's place	40	20 (SW1)	10 (SW2)	20	10 (SW2)	8 (SW3)	10	8 (SW3)	4 (SW4)	8	4 (SW4)	2 (SW5)	4	2 (SW5)	1 (SW6)	2	1 (SW6)	OFF (SW7)	1	OFF (SW7)	OFF
Station number	Ten's place	One's place																							
40	20 (SW1)	10 (SW2)																							
20	10 (SW2)	8 (SW3)																							
10	8 (SW3)	4 (SW4)																							
8	4 (SW4)	2 (SW5)																							
4	2 (SW5)	1 (SW6)																							
2	1 (SW6)	OFF (SW7)																							
1	OFF (SW7)	OFF																							
4)	Connector for CC-Link/LT interface Connector for CC-Link/LT communication line and module power supply.																								
5)	Connector for I/O interface MIL connector for connecting output signal, load power supply and external power supply of the output part.																								

No. Item	Description
6)	Hook for DIN rail Hook for installing the module on a DIN rail.

¹⁾ Set up using a slotted screwdriver with a tip width of 0.9 mm or less.

4. Handling Precautions

- When using a DIN rail, attach the DIN rail after taking the following items into consideration:
 - Applicable DIN rail types (conform to JIS C 2812) TH35-7.5Fe TH35-7.5Al
 - Interval between the DIN rail's installation screws
 Tighten the screws using a pitch of 200mm (7.87in.) or less when attaching a DIN rail.
- To attach the remote I/O module to the DIN rail, press the centerline area of the DIN rail hook beneath the module until a click is heard.
- When installing the remote I/O module into a panel, etc., provide 15mm (0.59 in.) or more of space between the top and bottom of the module and other structures or parts so that good ventilation and ease of operation when exchanging modules can be secured.

5. Wiring

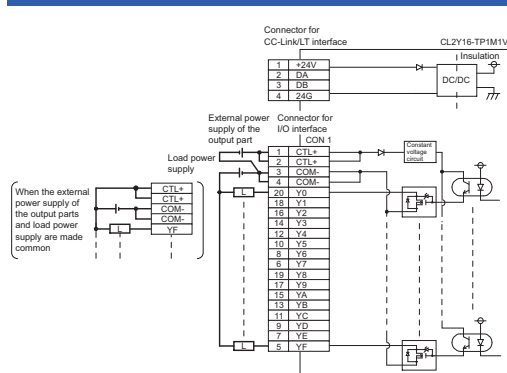

The power to the module is supplied via the power adapter. L'alimentation du module se fait via l'adaptateur d'alimentation.

English	French
When the external power supply of the output parts and load power supply are made common	Si on utilise la même alimentation électrique pour les sections sortie et pour la charge
Load power supply	Alimentation de charge
External power supply of the output part	Alimentation externe de la partie sortie
Connector for CC-Link/LT interface	Connecteur pour interface CC-Link/LT
Connector for I/O interface	Connecteur pour interface E/S
Insulation	Isolation
Constant voltage circuit	Circuit à tension constante

6. External Dimensions

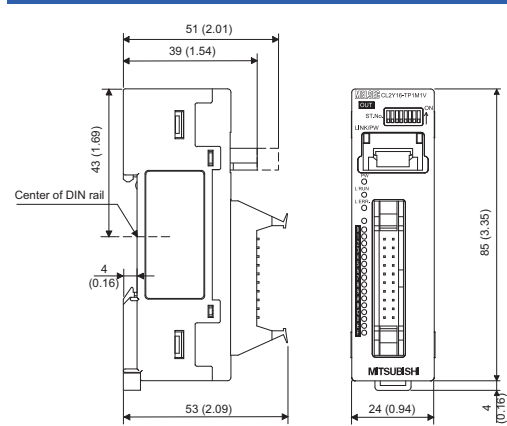

Unit: mm (inch)

WARRANTY

Mitsubishi will not be liable for damage caused by factors found not to be the cause of Mitsubishi; machine damage or lost profits caused by faults in the Mitsubishi products; damage, secondary damage, accident compensation caused by special factors unpredictable by Mitsubishi; damages to products other than Mitsubishi products; and to other duties.

Country/Region	Sales office/Tel
U.S.A	Mitsubishi Electric Automation Inc. 500 Corporate Woods Parkway Vernon Hills, IL 60061, U.S.A. Tel : +1-847-478-2100
Brazil	MELCO-TEC Rep. Com.e Assessoria Tecnica Ltda. Rua Correia Dias, 184, Edificio Paraiso Trade Center-8 andar Paraiso, Sao Paulo, SP Brazil Tel : +55-11-5908-9331
Germany	Mitsubishi Electric Europe B.V. German Branch Gothar Strasse 8 D-40880 Ratingen, GERMANY Tel : +49-2102-486-0
U.K	Mitsubishi Electric Europe B.V. UK Branch Travellers Lane, Hatfield, Hertfordshire., AL10 8XB, U.K. Tel : +44-1707-276100
Italy	Mitsubishi Electric Building, Milan Branch Centro Dir. Colleoni, Pal. Perso-Ing.2 Via Paracelso 12, I-20041 Agrate Brianza., Milano, Italy Tel : +39-039-60531
Spain	Mitsubishi Electric Europe B.V. Spanish Branch Carretera de Rubi 76-80, E-08190 Sant Cugat del Valles, Barcelona, Spain Tel : +34-93-595-1331
France	Mitsubishi Electric Europe B.V. French Branch 25, Boulevard des Bouvets, F-92741 Nanterre Cedex, France Tel : +33-1-5568-5568
South Africa	Circuit Breaker Industries Ltd. Private Bag 2016, ZA-1600 Isando, South Africa Tel : +27-11-929-2000
China	Mitsubishi Electric Automation (China) Ltd. 4/F Zhi Fu Plaza, No.80 Xin Chang Road, Shanghai 200003, China Tel : +86-21-6120-0808
Taiwan	Setsuyo Enterprise Co., Ltd. 6F No.105 Wu-Kung 3rd.Rd., Wu-Ku Hsiang, Taipei Hsine, Taiwan Tel : +886-2-2299-2499
Korea	Mitsubishi Electric Automation Korea Co., Ltd. 1480-6, Gayang-dong, Gangseo-ku Seoul 157-200, Korea Tel : +82-2-3660-9552
Singapore	Mitsubishi Electric Asia Pte, Ltd. 307 Alexandra Road #05-01/02, Mitsubishi Electric Building, Singapore 159943 Tel : +65-6470-2480
Thailand	Mitsubishi Electric Automation (Thailand) Co., Ltd. Bang-Chan Industrial Estate No.111 Moo 4, Serithai Rd, T.Kannayao, A.Kannayao, Bangkok 10230 Thailand Tel : +66-2-517-1326
Indonesia	P.T. Autoteknikno Sumber Makmur Muara Karang Selatan, Block A/Utara No.1 Kaw. No.11 Kawasan Industri Pergudangan Jakarta - Utara 14440, P.O.Box 5045 Jakarta, 11050 Indonesia Tel : +62-21-6630833
India	Messung Systems Pvt. Ltd. Electronic Sadan NO:III Unit No15, M.I.D.C Bhosari, Pune-411026, India Tel : +91-20-2712-3130
Australia	Mitsubishi Electric Australia Pty. Ltd. 34B Victoria Road, Rydalmere, N.S.W 2116, Australia Tel : +61-2-9684-7777

MITSUBISHI ELECTRIC CORPORATION
HEAD OFFICE: TOKYO BUILDING, 2-7-3 MARUNOUCHI, CHIYODA-KU, TOKYO 100-8310, JAPAN
NAGOYA WORKS: 1-14, YADA-MINAMI 5-CHOME, HIGASHI-KU, NAGOYA, JAPAN

When exported from Japan, this manual does not require application to the Ministry of Economy, Trade and Industry for service transaction permission.

Specifications subject to change without notice.